



3-PHASE STEPPER MOTOR DRIVE

3MC8H User manual

3 Phase digital stepper motor driver

3MC8H

■ Features

3MC8H 3phase digital stepper motor driver is a cost-effective, high performance step drives. The design is based on advanced digital current control technology, and features high torque, low noise, and low vibration. The running current, microstep resolution and other parameters are switch selectable. 3MC8H can be matched for 3phase 110mm and 130mm stepper motors.

- New ARM 32bit processor
- Idle Current setting
- Input Voltage VAC85-265
- Torque Ripple Smoothing
- Self Test and alarm function
- Resolution is 25600
- Output current reaches 8.0A
- CW/CCW and CW/Dir modes switches
- Signal input is 5-24VDC
- Microstep Emulation

■ Functional diagram

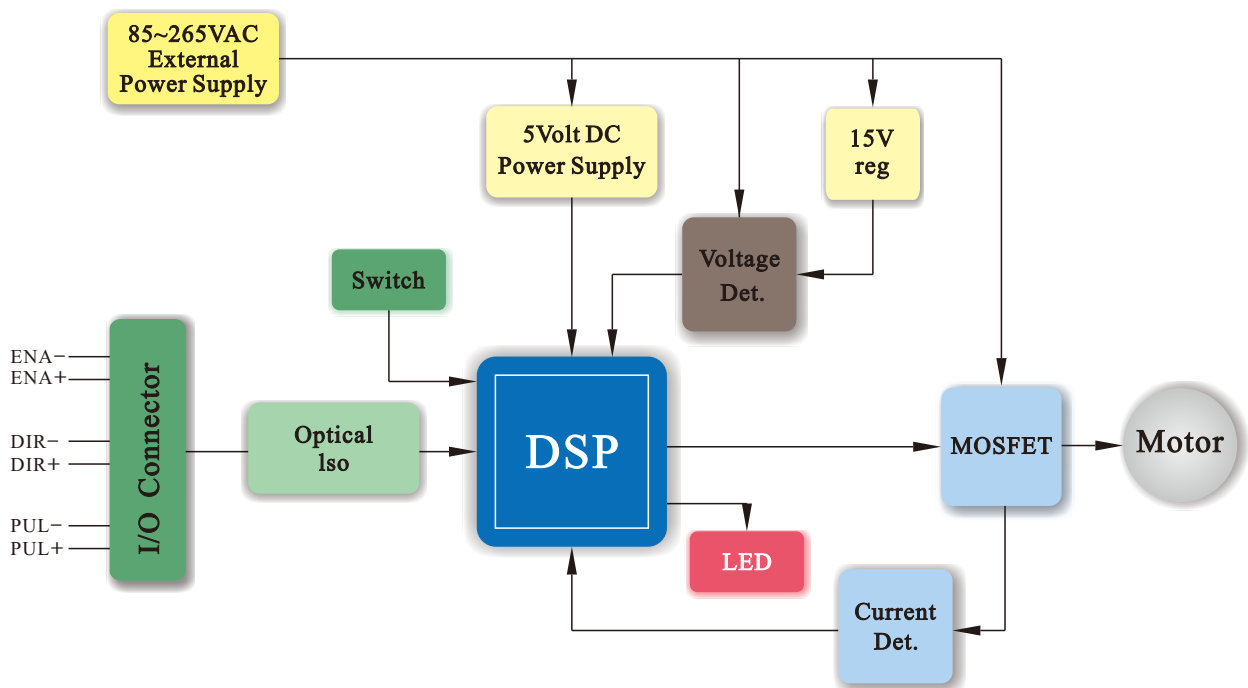

■ Electrical performance and environment indicators

● Electrical Specifications

Parameter	Min.	Typical	Max.	Unit
Power supply	85	220	265	VAC
Output Current	0.5	-	8.0	A
Step Frequency	1	-	1M	Hz
Step pulse width	250	-	5E+8	ns
Input Signal Voltage	3.6	5	24	VDC

● Environment Indicators

Heat Sinking Method	Natural cooling or fan-forced cooling
Atmosphere	Avoid dust, oily mist and corrosive air
Operating Temperature	0~40°C
Ambient Humidity	90% or less (non-condensing)
Storage Temperature	-10~70°C
Heat Sinking Method	5.9m/s ² maximum

■ Dimension (Units: mm)

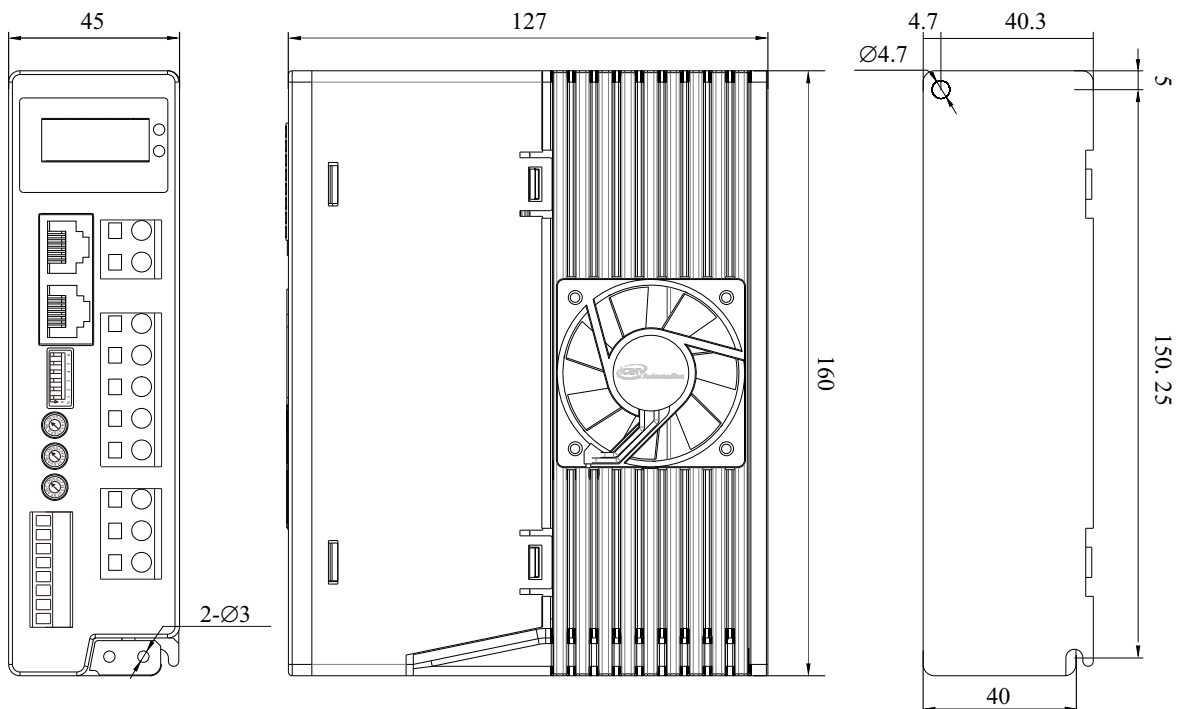

■ System Configuration

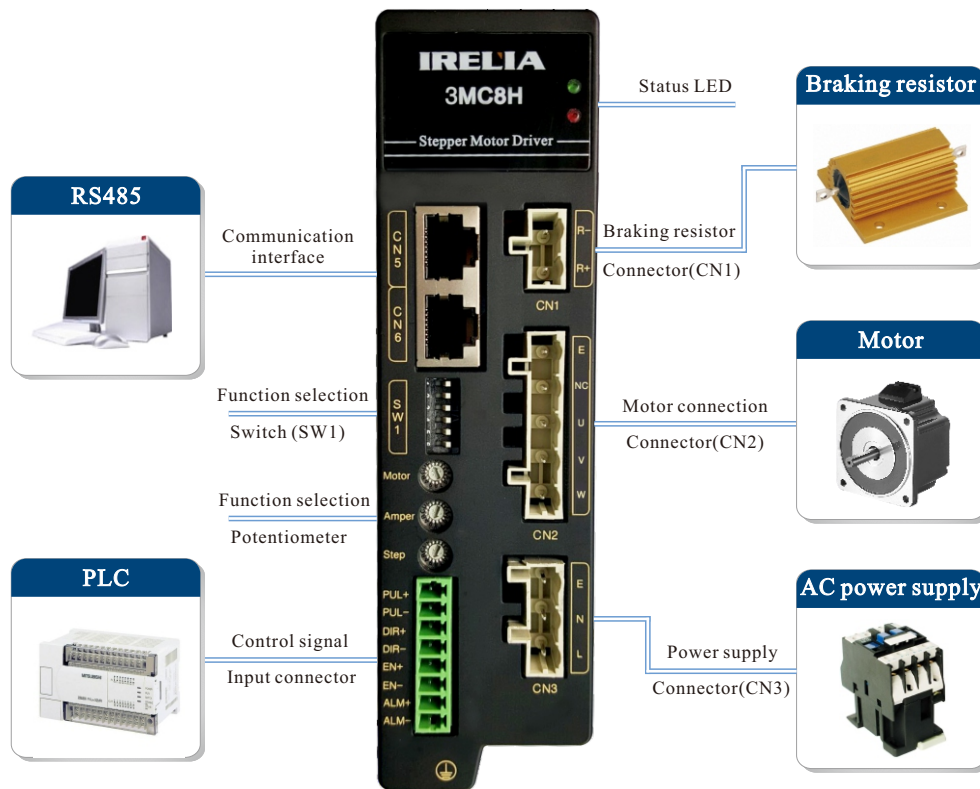

● Motor connector

CN2	Function description
E	FG
NC	NC
U	Motor phase U
V	Motor phase V
W	Motor phase W

● Power supply connector

CN3	Function description
E	EG
N	AC power supply (AC220-265V)
L	

● Function selection switches

Name	Function description
Motor	Motor parameter setting
Amper	Current setting
Step	Resolution setting

● Control signal connector

Connector	Function description
PUL+	Pulse input+ / CW pulse input+
PUL-	Pulse input- / CW pulse input-
DIR+	Direction signal input+ / CWW pulse input+
DIR-	Direction signal input- / CWW pulse input-
ENA+	Enable signal input+
ENA-	Enable signal input-
ALM+	Alarm output signal+
ALM-	Alarm output signal-

- Braking resistor connector

CN1	Name	Function description
R-	Braking resistor-	In the heavy load occasions and the braking process, inertia generates electricity, which could destroy the drive. To protect the driver, please connect the brake resistor.
R+	Braking resistor+	

- Function setting switch SW1

Name	Function description		
P1	Massager address setting (optional). If needed, please contact sales person.		
P2			
P3			
P4	Self testing	Self testing open : ON	Self testing closed: OFF
P5	Pulse&Dir input selection	Pulse+Dir : OFF	CW/CCW : ON
P6	Current Idle	Half current : OFF	Full current : ON

- Massager address connector (optional).

If needed, please contact sales person.

■ Power, motor and ground connection

CN1, CN2, CN3 connection

1. Put the wire into the connector using line pressing machine.
2. Loosen the line pressing machine, fix the wire.

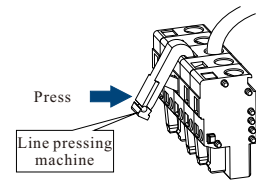

Notice: Don't connect when power is on in case electric shock.

● Protective earthing

Please use AWG24-16 wire to connect and connect E terminal of CN3 with ground in case electric shock.

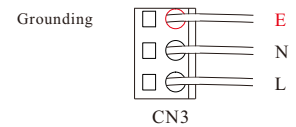

● Motor connection

Please connect CN2 and Motor FG in case of electric shock.

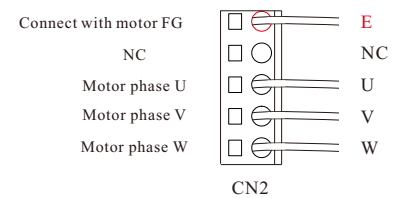

To change the direction of motor, customers only need to change the line sequence of one of U V W phases.

Star connection and triangular connection are available for 3 phase motors. Star connection is for low speed occasions and triangular connection is for high speed occasions.

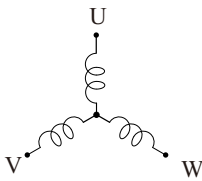

Star connection

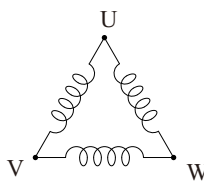

Triangular connection

Control signal input

The control signal is OC input; the voltage ranges DC5-24V. The largest step frequency is 200KHz and rising edge is valid.

Common anode

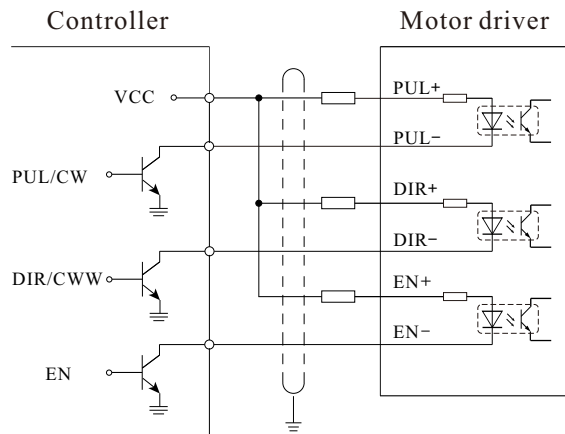

Common cathode

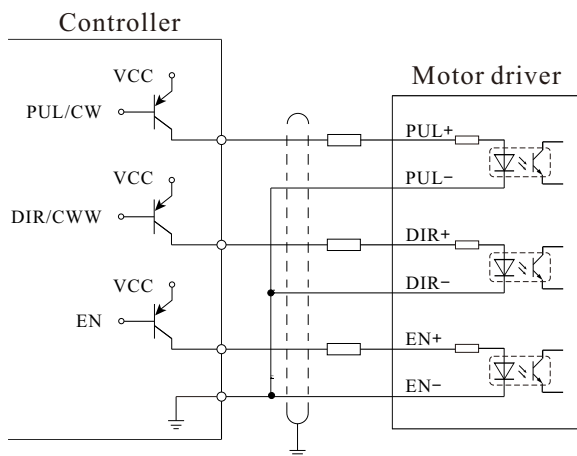

Difference

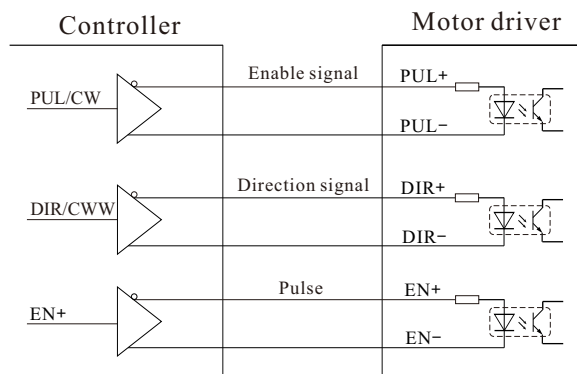

● Alarm signal output

Alarm signal output is OC. The maximum saturation voltage is 30V and maximum saturation current is 100mA.

Common anode

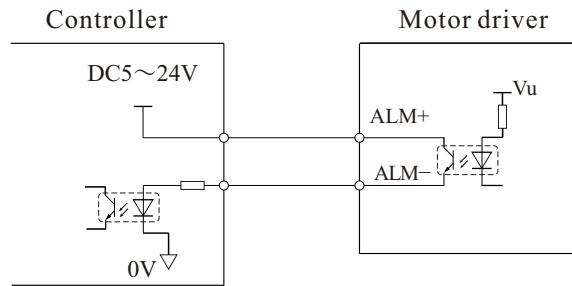

Common cathode

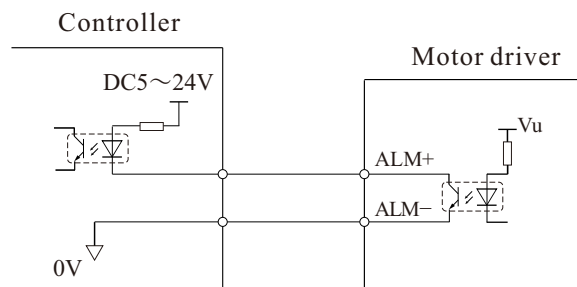

Relay

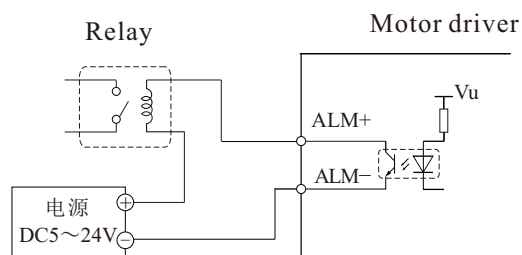

Function setting

Pulse Input Mode

CW/CCW mode: P5=ON
 PUL/DIR mode: P5=OFF (factory setting)

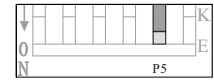

The setting will take effect after recycle the power

CW/CCW Pulse

When pulse is input at PUL/CW terminal, the motor will rotate by one step in one direction.

When pulse is input at DIR/CWW terminal, the motor will rotate by one step in the other direction.

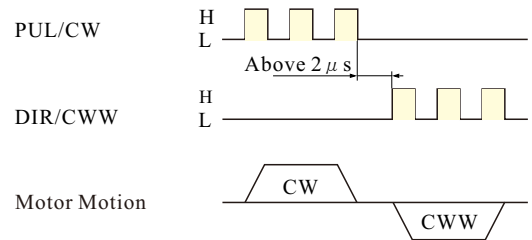

Pulse & Direction

When pulse is input at PUL terminal, and DIR terminal is high voltage, the motor will rotate by one step in one direction. When pulse is input at PUL terminal, and DIR terminal is low voltage, the motor will rotate by one step in the other direction.

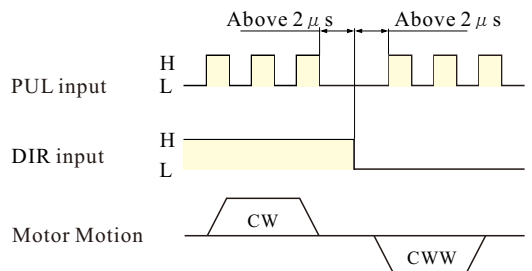

Self Test

Setting switch P4 to ON after the drive is powered up will cause the drive to perform a self test rotate the motor back and forth, two turns in each direction, setting switch P4 to OFF will disable this feature.

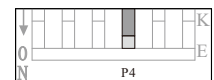

Idle Current

The running current of the motor driver is automatically reduced whenever the motor hasn't moved for 1 second. Setting the P6 switch to ON reduces the current to 50% of its running value. Setting this switch to OFF maintains 90% of the running current. This 90% setting is useful when a high holding torque is required. To minimize motor and drive heating it is highly recommended that the idle current reduction feature be set to 50% unless the application requires the higher setting.

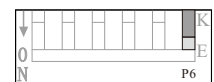

● EN Input

The EN input enables or disables the drive amplifier. When EN input is ON the drive amplifier. When EN input is ON the drive amplifier is deactivated. All the mosfets will shut down, and the motor will be free. When EN input is OFF, the drive is activated. A falling signal into the EN input will reset the error status and activate the drive amplifier again.

● Anti Resonance

To optimize the system performance to gain fastest feedback, customers are allowed to select parameters to match the motor size, motor inductance.

Switch	0	1	2	3	4	5	6	7
Flange size(mm)	57	57	60	60	86	86	86	86
Switch	8	9	A	B	C	D	E	F
Flange size(mm)	110	110	110	110	130	130	130	130



Motot

The recommended motors are our motors. If performance is not good after switching according to the above tab, please contact us with motor parameters.

● Running current setting

The output current of the driver is set by the Amper potentiometer and can be changed as necessary. Normally, customers set the current same with the motor rated current.

Switch	0	1	2	3	4	5	6	7
Peak running current	0.5A	1.0A	1.5A	2.0A	2.5A	3.0A	3.5A	4.0A
Switch	8	9	A	B	C	D	E	F
Peak running current	4.5A	5.0A	5.5A	6.0A	6.5A	7.0A	7.5A	8.0A



Amper

● Microstepping









The microstep resolution is set by the Step potentiometer. There are 16 settings.

拨码	0	1	2	3	4	5	6	7
细分 (p/rev)	200	400	800	1600	3200	6400	12800	25600
拨码	8	9	A	B	C	D	E	F
细分 (p/rev)	1000	2000	4000	5000	8000	10000	20000	25000



Step

■ LED Error Codes

LED	Motion status/Alarm
 Flashing green	Normal
 2 green, 2red circulation flashing	Over current
 2 green, 3red circulation flashing	Open motor winding
 2 green, 4red circulation flashing	Over voltage
 2 green, 5red circulation flashing	Under voltage
 1 green, 3red circulation flashing	Internal supply voltage is insufficient
 1 green, 2red circulation flashing	Over temperature protection
 Flashing red	Motor enabled



Turning on power is banned when driver hasn't been connected with motor, power positive and negative pole will ruin the driver.

■ Troubleshooting

Situation	Possible cause	Suggestion
Motor disabled	Motor is in EN status	Input a falling signal into the EN input.
	Wrong wiring	Check the wiring and make sure connection is right
	Output current is low	Set the switch to set suitable current
	Microstep resolution is low	Set the resolution higher
	No pulse signal input	Make sure pulse signal input
	Input pulse signal is weak	Make sure the input signal voltage DC5-24V, 7-16Ma
	CW and CWW signal are input simultaneously	Make sure the pulse input mode
	No power supply	Make sure power supply works
Motor motion is not smooth	Motor speed is in resonance zone	Set the microstep resolution higher
	External interference exists	Make sure the interference source and interference position
The amount of movement of the motor varies with the set value	Microstep resolution is not right	Set the right resolution
	Output current is low	Set the switch to set suitable current
Motor out of step	Acceleration / deceleration time is too short	Set the Acceleration / deceleration time longer
	Rated torque is low	Select suitable motor
	Start frequency is too high	set the frequency lower when start
	Current value is low	Set the current higher
	Voltage value is low	Set the voltage higher
	External interference exists	Make sure the interference source and interference position

Recommended motor

- 3 phase hybrid nema 42 stepper motor

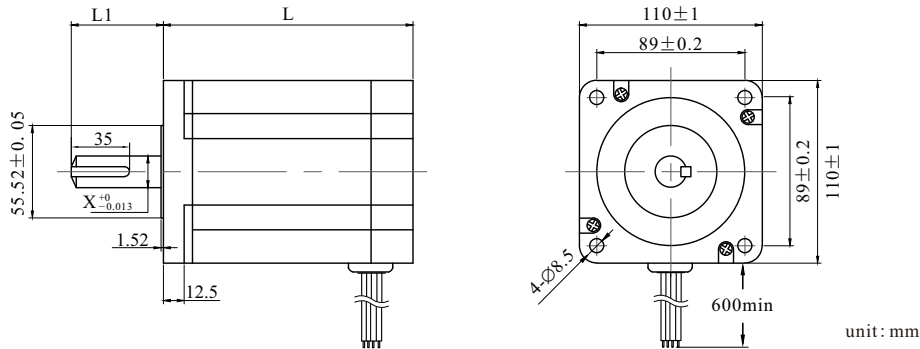

Model	Holding Torque(Nm)	Current/phase(A)	Resistance (Ω)	Inductance (mH)	Diameter of axle X(mm)	Axial length L1(mm)	Motor Length L(mm)
110H3P0843A3	8	4.3	1.31	17.1	19	37.5	136
110H3P1260A3	12	6.0	0.66	9.2	19	37.5	150
110H3P1665A3	16	6.5	0.63	8.9	19	37.5	181
110H3P2070A3	20	7.0	0.67	10.4	19	37.5	218

Driver:3MC8H Current:4.3A — AC220V
 Motor:110H3P0843A3 Subdivision: 3200 Step/r

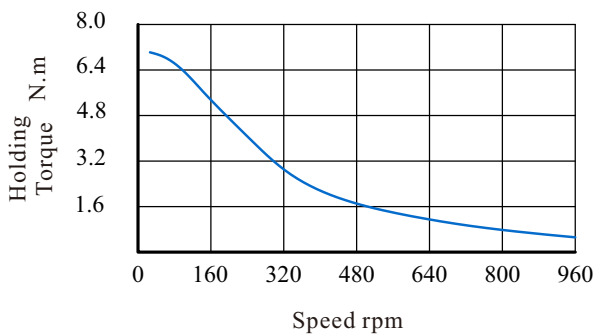

Driver:3MC8H Current:6.0A — AC220V
 Motor:110H3P1260A3 Subdivision: 3200 Step/r

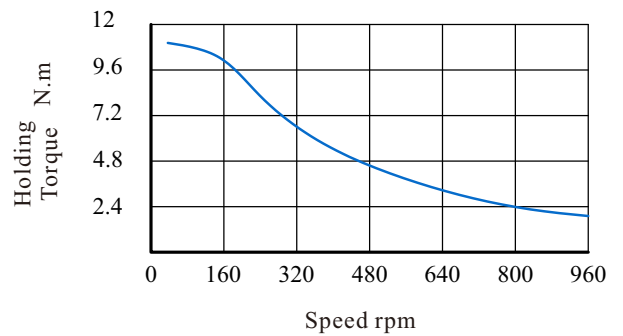

Driver:3MC8H Current:6.5A — AC220V
 Motor:110H3P1665A3 Subdivision: 3200 Step/r

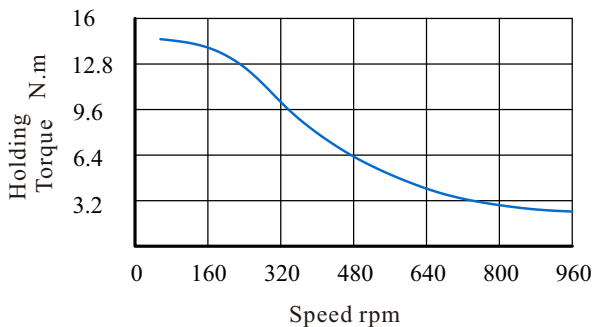

Driver:3MC8H Current:7.0A — AC220V
 Motor:110H3P2070A3 Subdivision: 3200 Step/r

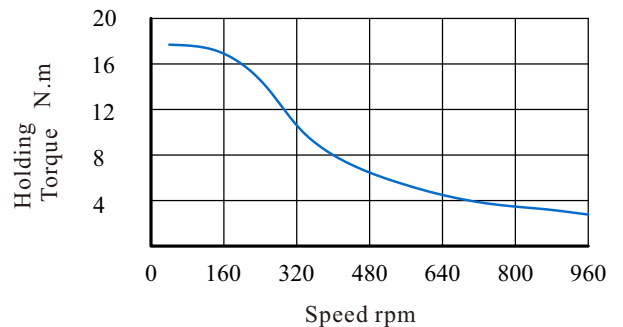

● 3 phase hybrid nema 51 stepper motor

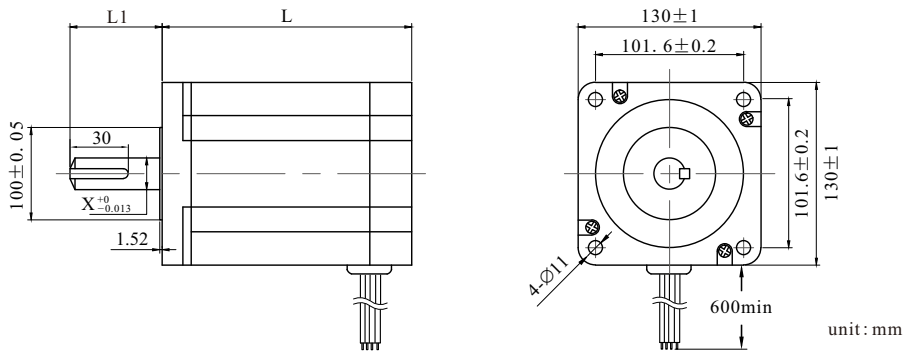

Model	Holding Torque(Nm)	Current/phase(A)	Resistance (Ω)	Inductance (mH)	Diameter of axle X(mm)	Diameter of axle X(mm)	Motor Length L(mm)
130H3P2068A3	20	6.8	0.62	7.8	24	49.5	168
130H3P2868A3	28	6.8	0.79	10.8	24	49.5	203
130H3P3568A3	35	6.8	0.97	14.2	24	49.5	238
130H3P5068A3	50	6.8	1.12	18.9	24	49.5	285

Driver:3MC8H Current:6.8A — AC220V
Motor:130H3P2068A3 Subdivision: 3200 Step/r

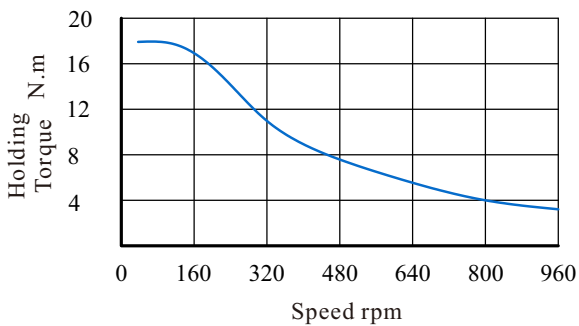

Driver:3MC8H Current:6.8A — AC220V
Motor:130H3P2868A3 Subdivision: 3200 Step/r

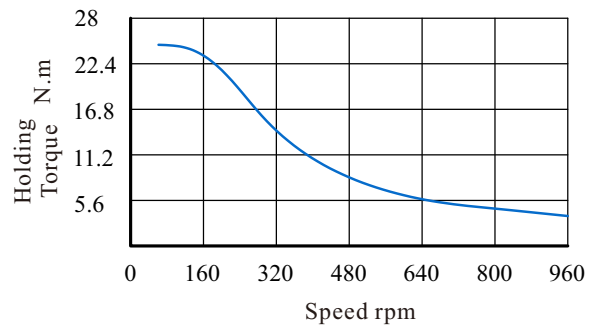

Driver:3MC8H Current:6.8A — AC220V
Motor:130H3P3568A3 Subdivision: 3200 Step/r

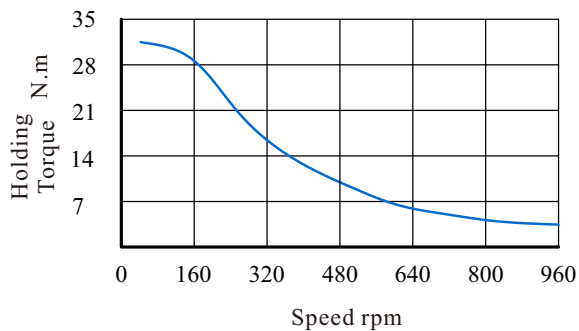

驱动器: 3MC8H 电流: 6.8A — 220V
电机: 130H3P5068A3 细分: 3200 步 / 转

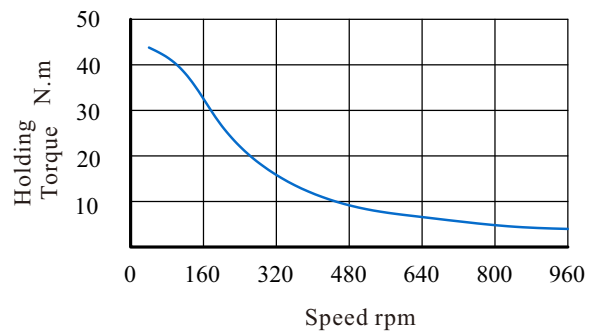

After sale service

Warranty period

Dongguan ICAN Technology provides warranty for 1 year from the date of shipping.

Maintenance process

- 1) Get the maintenance permission
 - 2) Ship the package to the following address: 4/F, Block B, RuiLian Zhenxing Industrial Park, Wanjiang District, Dongguan City, Guangdong Province
- Tel: 86-0769-22327568

Return policy

1. After use or man-made damage condition (etc, wrong wiring), no return
2. ICAN Technology guarantees the product quality, but product incompatibility is not in the return or maintain condition.
3. Customers don't use the products under the specified electrical performance and environment indicators, no maintain condition



Dongguan ICAN Technology Co., Ltd

Add:4/F, Block B, RuiLian Zhenxing Industrial Park, Wanjiang District, Dongguan City, Guangdong Province, China

Tel: 086-0769-22327568

Fax:086-0769-22327578

Website: ican-tech.en.alibaba.com



Scan the QR code to follow us on Wechat