

2-PHASE STEPPER MOTOR DRIVE

MR2

User manual

2 Phase digital stepper motor driver

MR2

■ Features

MR2 2phase digital stepper motor driver is a cost-effective, high performance step drives. The design is based on advanced digital current control technology, and features high torque, low noise, and low vibration. The running current, microstep resolution and other parameters are switch selectable. MR2 can be matched for 28mm, 35mm, 39mm, 42mm and 57mm motors.

- New ARM 32bit processor
- Input pulse frequency is 2MHz
- Input Voltage VDC12-50
- Torque Ripple Smoothing
- Self Test and alarm function
- Resolution is 25600
- Output current reaches 2.5A
- CW/CCW and CW/Dir modes switches
- Signal input is 5-24VDC
- Microstep Emulation

■ Functional diagram

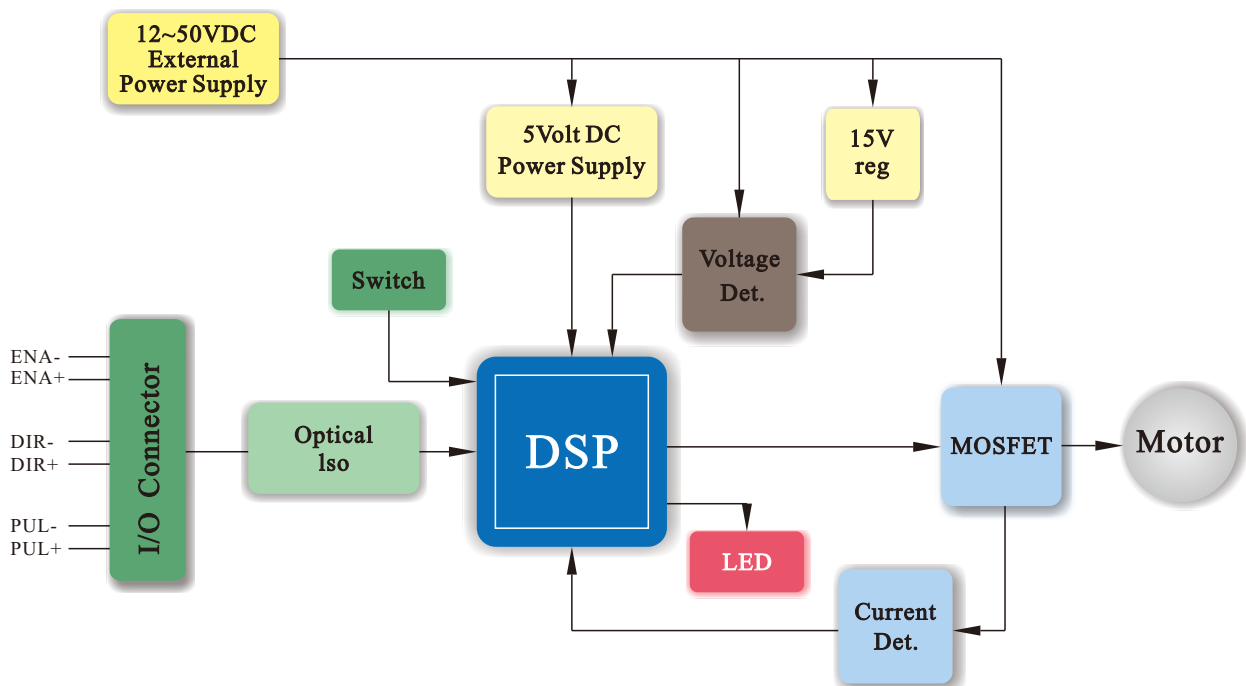

■ Electrical performance and environment indicators

● Electrical Specifications

Parameter	Min.	Typical	Max.	Unit
Power supply	12	24	50	VDC
Output Current	0.3	-	2.5	A
Step Frequency	1	-	200K	Hz
Step pulse width	250	-	5E+8	ns
Input Signal Voltage	3.3	5	24	VDC

● Environment Indicators

Heat Sinking Method	Natural cooling or fan-forced cooling
Atmosphere	Avoid dust, oily mist and corrosive air
Operating Temperature	0~40°C
Ambient Humidity	90% or less (non-condensing)
Storage Temperature	-10~70°C
Vibration Resistance	5.9m/s ² maximum

■ Dimension (Units: mm)

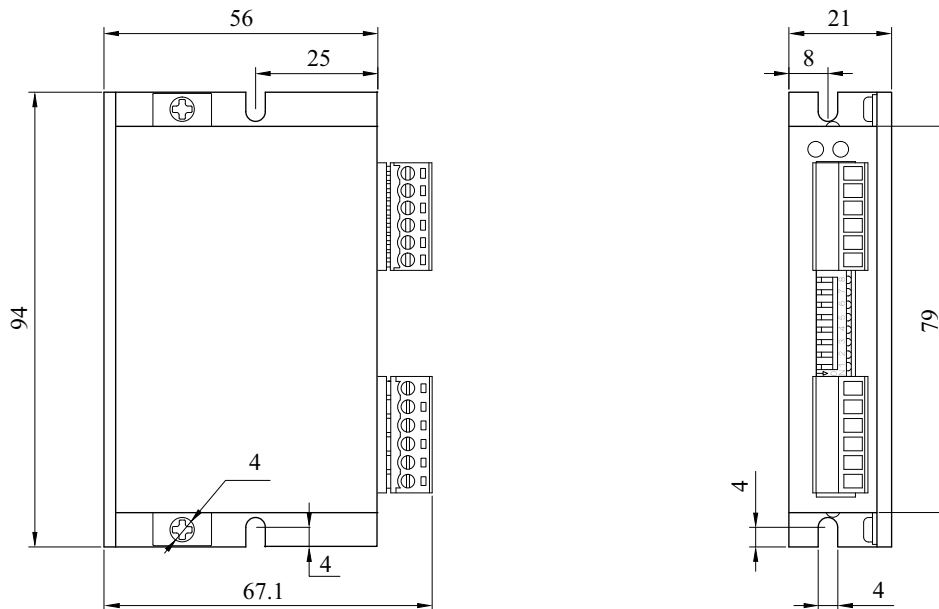

System Configuration

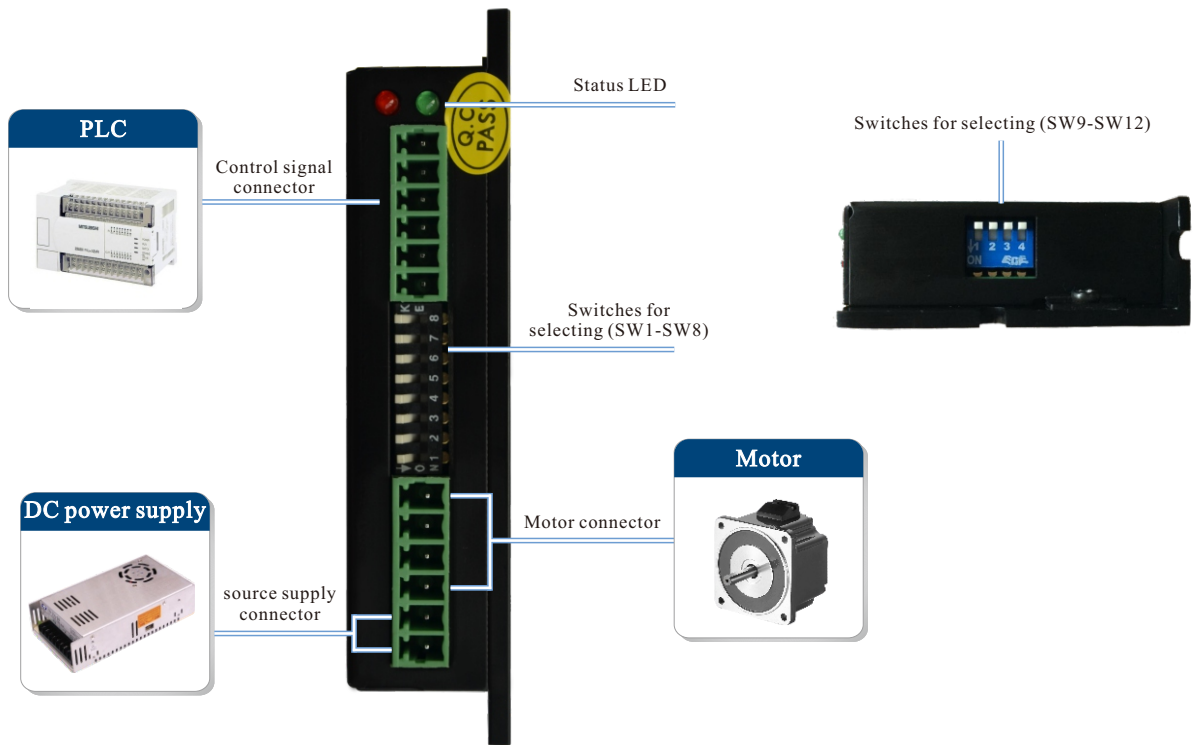

Control signal connector

Connector	Function description
ENA-	Enable signal input-
ENA+	Enable signal input+
DIR-	Direction signal input-/CWW pulse input-
DIR+	Direction signal input+/CWW pulse input+
PUL-	Pulse input-/CW pulse input-
PUL+	Pulse input+/CW pulse input+

Function selection switches

Nama	Function description
SW1~SW3	Running current setting
SW4	Idle current setting
SW5~SW8	Micro stepping setting

Motor connector

Connector	Function description
B-	Motor phase B
B+	
A-	Motor phase A
A+	

Power supply connector

Connector	Function description
V-	Power supply-
V+	Power supply+(DC12-50V)

Function selection switches

Nama	Function description
SW9	Single/double pulse matching
SW10	Self test
SW11~SW12	Motor parameter selection

■ Connecting the motor

To change the direction of motor, customers only need to change the line sequence of Phase A or Phase B. Customer can select different modes of connection according to different user environment.

● 6 leads series motor

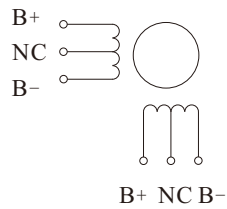

High torque output

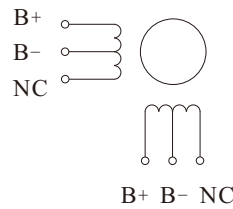

High speed output

● 8 leads series motor

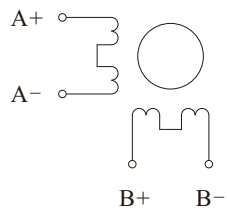

In series (High torque output)

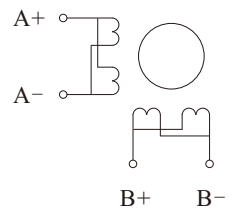

In parallel (High speed output)

Control signal input

The control signal is OC input; the voltage ranges DC5-24V. The largest step frequency is 200KHz and rising edge is valid.

Common anode

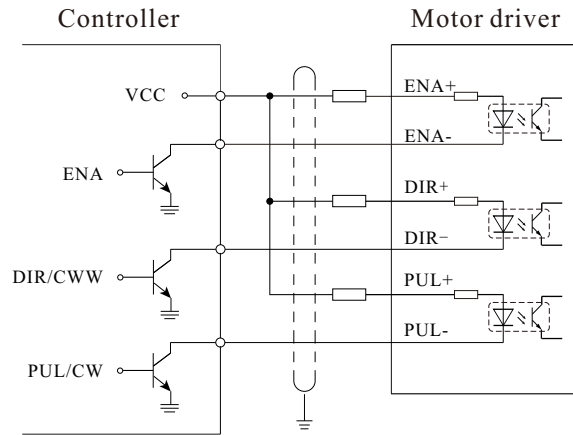

Common cathode

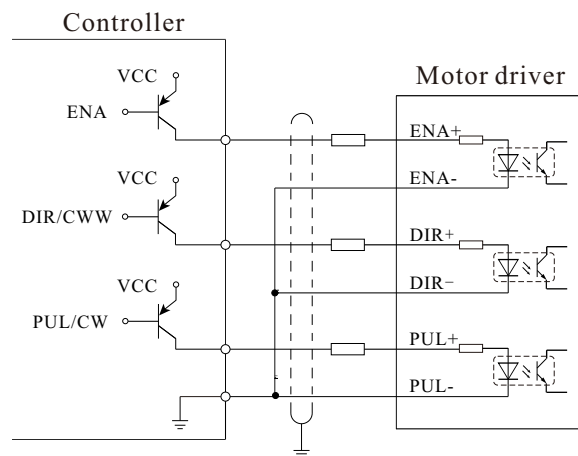

Difference

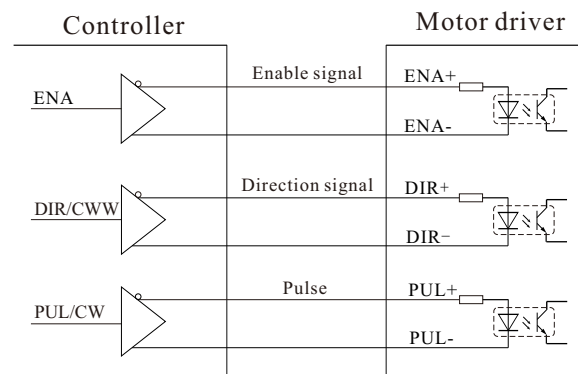

Function setting

Pulse Input Mode

CW/CCW mode: SW9=ON
 PUL/DIR mode: SW9=OFF (factory setting)



The setting will take effect after recycle the power

CW/CCW Pulse

When pulse is input at PUL/CW terminal, the motor will rotate by one step in one direction.

When pulse is input at DIR/CWW terminal, the motor will rotate by one step in the other direction.

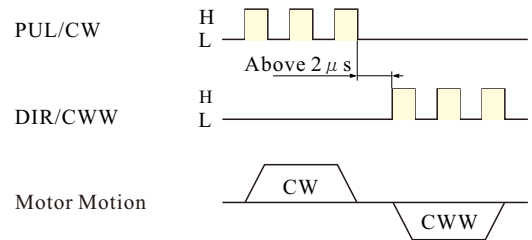

Pulse & Direction

When pulse is input at PUL terminal, and DIR terminal is high voltage, the motor will rotate by one step in one direction. When pulse is input at PUL terminal, and DIR terminal is low voltage, the motor will rotate by one step in the other direction.

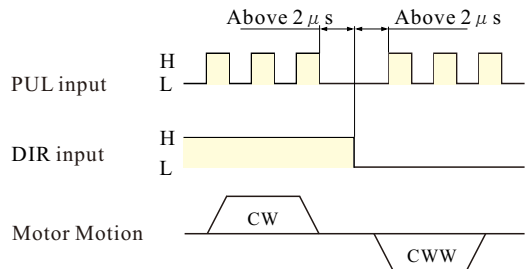

Self Test

Setting switch SW10 to ON after the drive is powered up will cause the drive to perform a self test rotate the motor back and forth, two turns in each direction, setting switch SW9 to OFF will disable this feature.

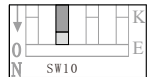

Anti Resonance

To optimize the system performance to gain fastest feedback, customers are allowed to select parameters (based on SW11 and SW12) to match the motor size, motor inductance. When motor has high torque and high inductance, customers are advised to set SW11=OFF, SW12=OFF (factory setting) When motor has low torque and low inductance, customers are advised to set SW11=ON, SW12=ON



Idle Current

The running current of the motor driver is automatically reduced whenever the motor hasn't moved for 1 second. Setting the SW4 switch to ON reduces the current to 50% of its running value. Setting this switch to OFF maintains 90% of the running current. This 90% setting is useful when a high holding torque is required. To minimize motor and drive heating it is highly recommended that the idle current reduction feature be set to 50% unless the application requires the higher setting.

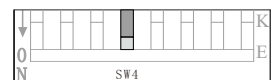

● EN Input

The EN input enables or disables the drive amplifier. When EN input is ON the drive amplifier. When EN input is ON the drive amplifier is deactivated. All the mosfets will shut down, and the motor will be free. When EN input is OFF, the drive is activated. A falling signal into the EN input will reset the error status and activate the drive amplifier again.

● Running current

The output current of the driver is set by the SW1, SW2 and SW3 switches and can be changed as necessary. There are 8 settings available according to the ON/OFF combination of the switches. Normally, customers set the current same with the motor rated current.

Peak running current	SW1	SW2	SW3
0.3A	OFF	OFF	OFF
0.5A	ON	OFF	OFF
0.8A	OFF	ON	OFF
1.2A	ON	ON	OFF
1.5A	OFF	OFF	ON
2.0A	ON	OFF	ON
2.2A	OFF	ON	ON
2.5A	ON	ON	ON

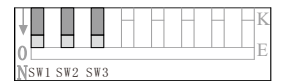





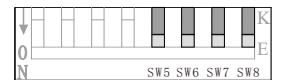

● Microstepping

The microstep resolution is set by the SW5, SW6, SW7 and SW8 switches. There are 16 settings.

Subdivision (Step/r)	SW5	SW6	SW7	SW8
200	ON	ON	ON	ON
400	OFF	ON	ON	ON
800	ON	OFF	ON	ON
1600	OFF	OFF	ON	ON
3200	ON	ON	OFF	ON
6400	OFF	ON	OFF	ON
12800	ON	OFF	OFF	ON
25600	OFF	OFF	OFF	ON
1000	ON	ON	ON	OFF
2000	OFF	ON	ON	OFF
4000	ON	OFF	ON	OFF
5000	OFF	OFF	ON	OFF
8000	ON	ON	OFF	OFF
10000	OFF	ON	OFF	OFF
20000	ON	OFF	OFF	OFF
25000	OFF	OFF	OFF	OFF



■ LED Error Codes

LED	Motion status/Alarm
 Flashing green	Normal
 2 green, 2red circulation flashing	Over current
 2 green, 3red circulation flashing	Open motor winding
 2 green, 4red circulation flashing	Over voltage
 2 green, 5red circulation flashing	Under voltage
 Flashing red	Motor enabled



Turning on power is banned when driver hasn't been connected with motor, power positive and negative pole will ruin the driver.

■ Troubleshooting

Situation	Possible cause	Suggestion
Motor disabled	Motor is in EN status	Input a falling signal into the EN input.
	Wrong wiring	Check the wiring and make sure connection is right
	Output current is low	Set the switch to set suitable current
	Microstep resolution is low	Set the resolution higher
	No pulse signal input	Make sure pulse signal input
	Input pulse signal is weak	Make sure the input signal voltage DC5-24V, 7-16Ma
	CW and CWW signal are input simultaneously	Make sure the pulse input mode
	No power supply	Make sure power supply works
Motor motion is not smooth	Motor speed is in resonance zone	Set the microstep resolution higher
	External interference exists	Make sure the interference source and interference position
The amount of movement of the motor varies with the set value	Microstep resolution is not right	Set the right resolution
	Output current is low	Set the switch to set suitable current
Motor out of step	Acceleration / deceleration time is too short	Set the Acceleration / deceleration time longer
	Rated torque is low	Select suitable motor
	Start frequency is too high	set the frequency lower when start
	Current value is low	Set the current higher
	Voltage value is low	Set the voltage higher
	External interference exists	Make sure the interference source and interference position

■ Recommended motor

- 2 phase hybrid nema 11 stepper motor

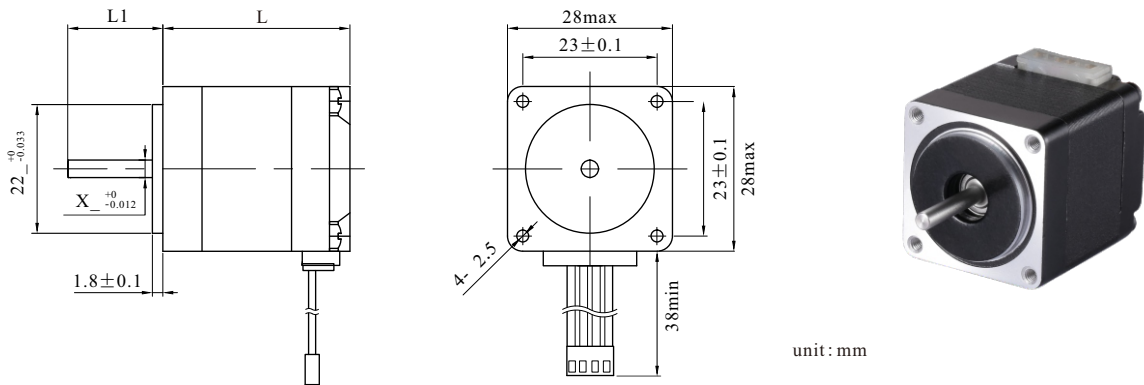

Model	Holding Torque(Nm)	Current/phase(A)	Resistance (Ω)	Inductance (mH)	Diameter of axle X(mm)	Axial length L1(mm)	Motor Length L(mm)
28H2P3205A4	0.06	0.45	11	6.9	3	13.8	32
28H2P4509A6	0.075	0.95	3.4	1.2	5	19.8	45

Driver:MR2 Current:0.3A — DC24V
 Motor:28H2P3205A4 Subdivision: 3200 Step/r

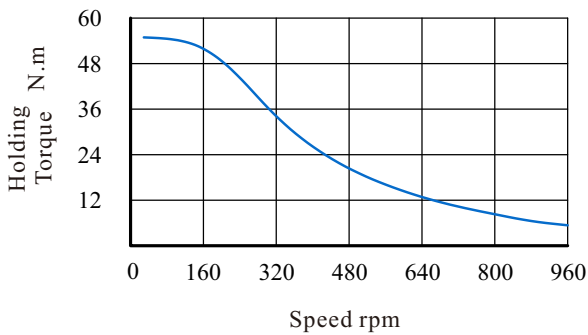

Driver:MR2 Current:0.8A — DC24V
 Motor:28H2P4509A6 Subdivision: 3200 Step/r

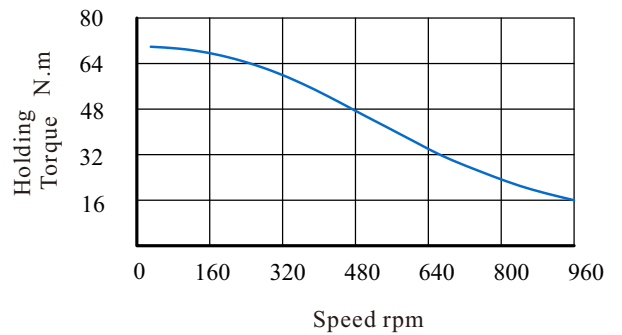

● 2 phase hybrid nema 14 stepper motor

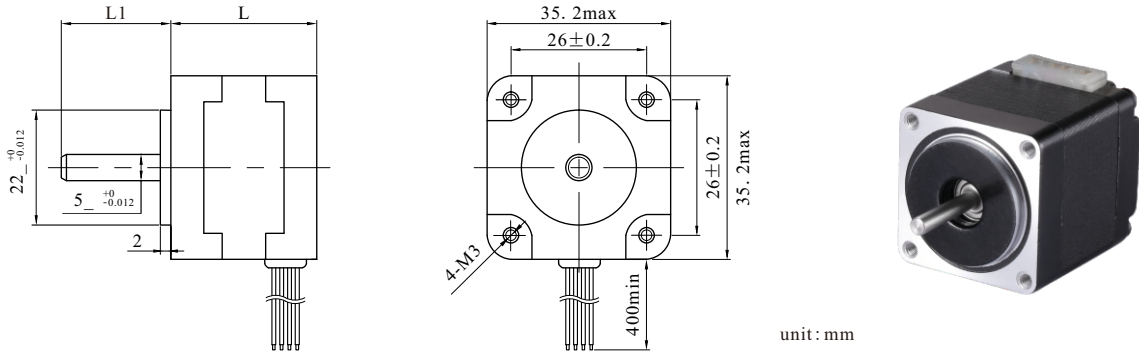

Model	Holding Torque(Nm)	Current/phase(A)	Resistance (Ω)	Inductance (mH)	Diameter of axle X(mm)	Axial length L1(mm)	Motor Length L(mm)
35H2P2803A4	0.11	0.3	40	1.6	5	21	28
35H2P2810A4	0.125	1.0	3.5	3.5	5	20	28

Driver:MR2 Current:0.5A — DC24V
 Motor:35H2P2803A4 Subdivision: 3200 Step/r

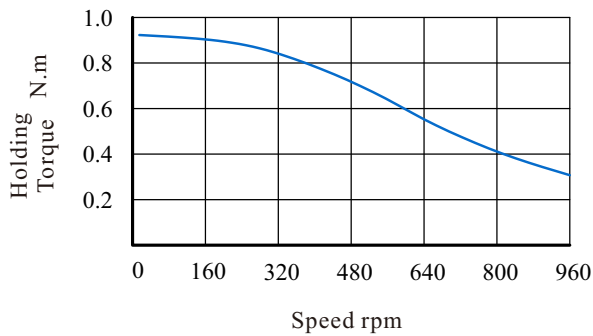

Driver:MR2 Current:0.5A — DC24V
 Motor:35H2P2810A4 Subdivision: 3200 Step/r

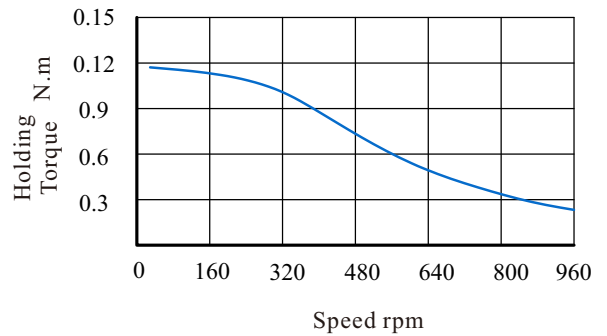

● 2 phase hybrid nema 17 stepper motor

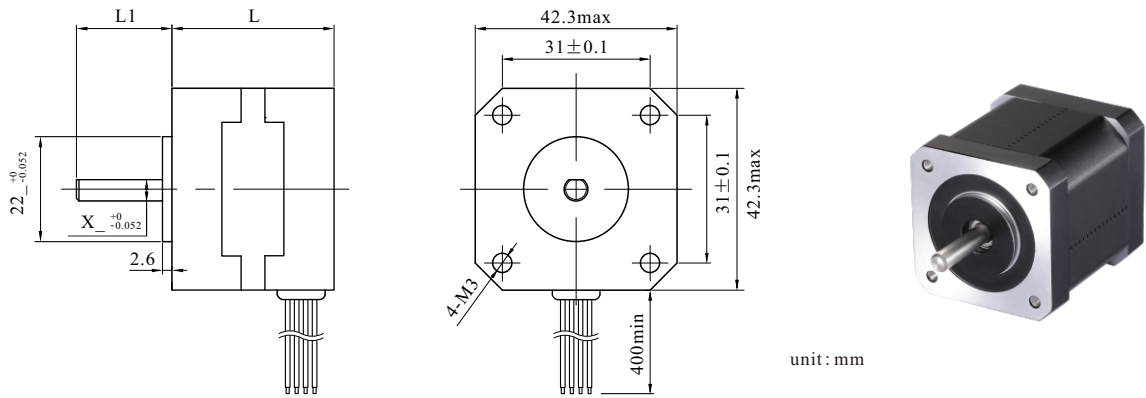

Model	Holding Torque(Nm)	Current/phase(A)	Resistance (Ω)	Inductance (mH)	Diameter of axle X(mm)	Axial length L1(mm)	Motor Length L(mm)
42H2P3412A4	0.19	1.2	3.2	4.4	5	20.6	34
42H2P4010A4	0.35	1.0	5.7	9.0	5	20.6	40
42H2P4412A4	0.35	1.2	2.7	6.0	5	20.6	44
42H2P4812A4	0.45	1.2	3.2	6.0	5	20.6	48

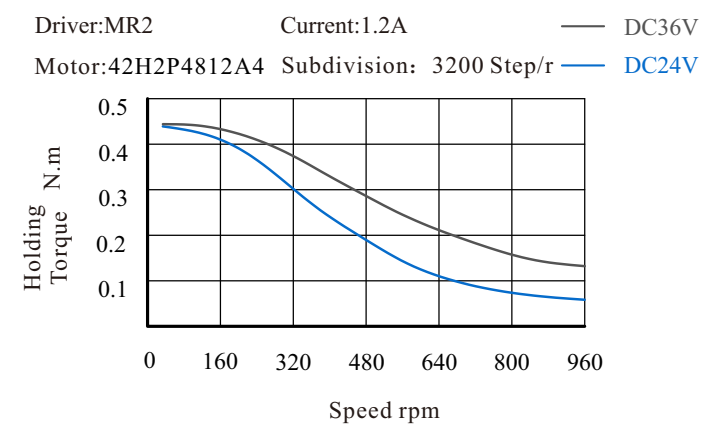
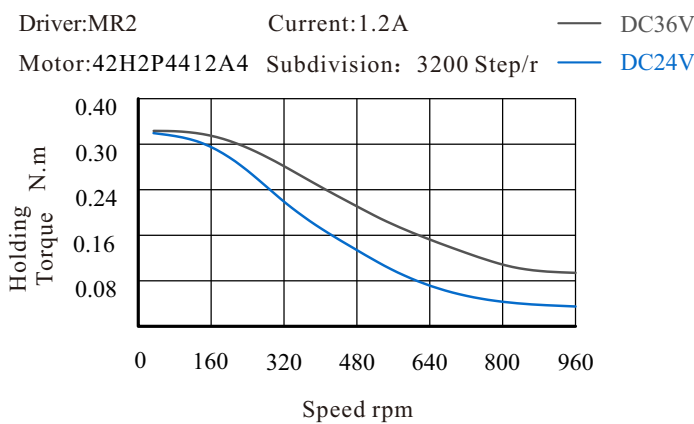
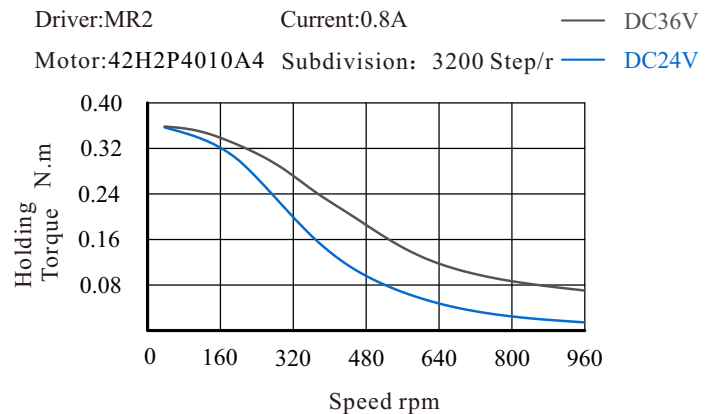
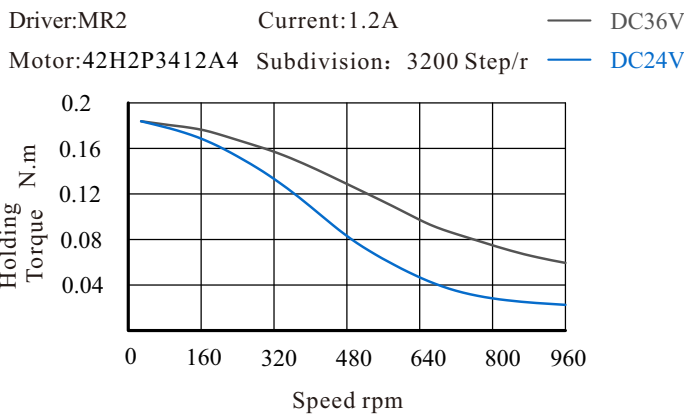

After sale service

Warranty period

Dongguan ICAN Technology provides warranty for 1 year from the date of shipping.

Maintenance process

- 1) Get the maintenance permission
 - 2) Ship the package to the following address: 4/F, Block B, RuiLian Zhenxing Industrial Park, Wanjiang District, Dongguan City, Guangdong Province
- Tel: 86-0769-22327568

Return policy

1. After use or man-made damage condition (etc, wrong wiring), no return
2. ICAN Technology guarantees the product quality, but product incompatibility is not in the return or maintain condition.
3. Customers don't use the products under the specified electrical performance and environment indicators, no maintain condition



Dongguan ICAN Technology Co., Ltd

Add:4/F, Block B, RuiLian Zhenxing Industrial Park, Wanjiang District, Dongguan City, Guangdong Province, China

Tel: 086-0769-22327568

Fax:086-0769-22327578

Website: ican-tech.en.alibaba.com



Scan the QR code to follow us on Wechat