



# CLOSED LOOP STEPPER MOTOR DRIVE

## SS42 User manual

## Closed Loop Stepper Motor Drive

# SS42

### Brief introduction

With high performance encoder, SS42 stepper servo driver gives position feedback signal to Cortex-M4 ARM processor and adjust the location every 50us. It has more accurate control both while running and static positioning compared with many other similar products. SS42 is used for 42mm closed loop stepper motor. The Step-Servo is an innovative revolution for the world of stepper motor, it enhances the stepper motors with servo technology to create a product with exceptional feature and broad capability.

- New Cortex-M4 ARM 32bit processor
- Smooth & Accurate
- High Torque
- Output current 2A
- Easy Tuning
- Closed loop
- Low Heating/High Efficiency
- Fast Response
- Resolution is 25600
- Pulse&Dir and CW/CCW control

### Functional diagram

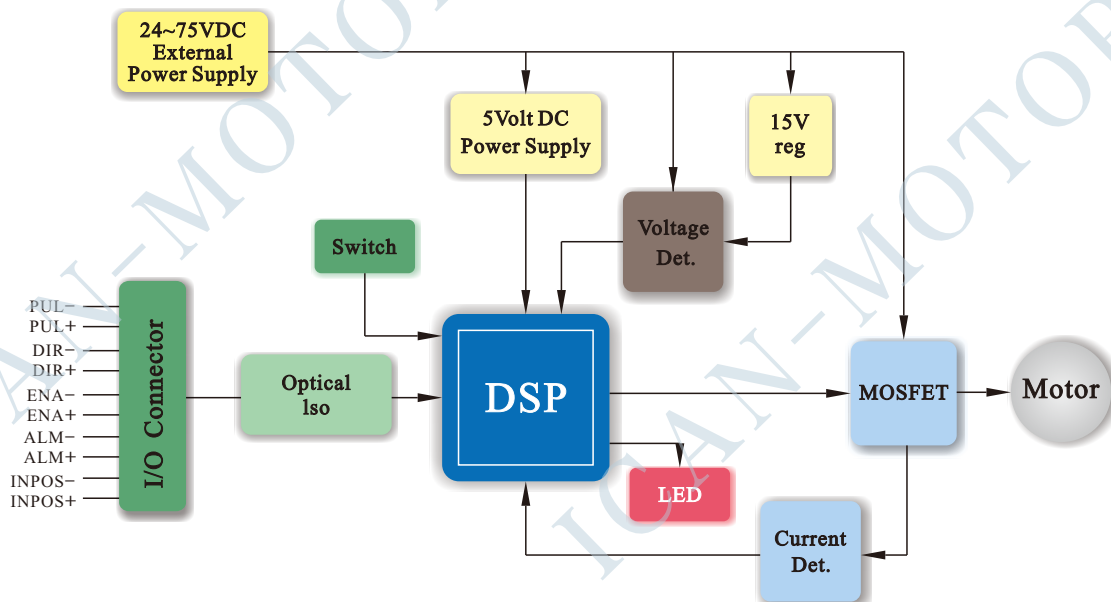

## ■ Electrical performance and environment indicators

### ● Electrical Specifications

Parameter	Min.	Typical	Max.	Unit
Power supply	24	48	75	VDC
Output Current	0.1	-	2.0	A
Input pulse frequency	1	-	500K	Hz
Input pulse width	250	-	5E+8	ns
Direction signal width	62.5	-	-	μs
Input signal voltage	3.6	5	24	VDC
Output Signal voltage	-	-	100	mA
Output signal current	-	-	30	vdc

### ● Environment Indicators

Heat Sinking Method	Natural cooling or fan-forced cooling
Atmosphere	Avoid dust, oily mist and corrosive air
Operating Temperature	- 10~40°C
Ambient Humidity	90% or less (non-condensing)
Storage Temperature	- 10 ~70°C
Vibration Resistance	5.9m/s <sup>2</sup> maximum

## ■ Dimension (Units: mm)

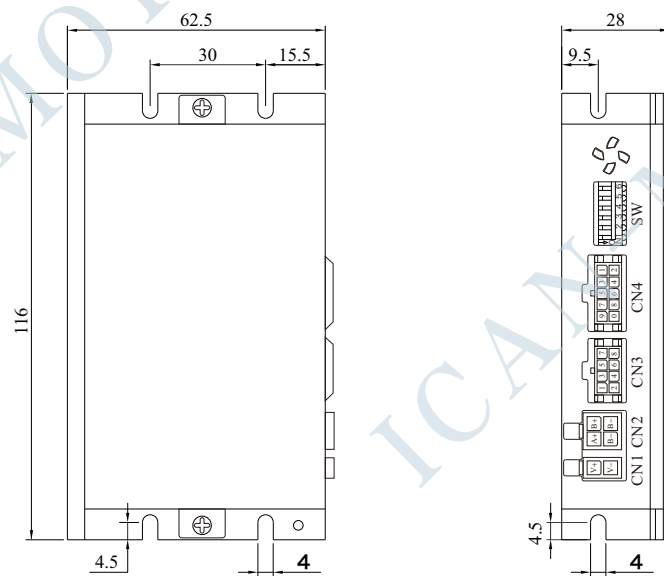

## Drive interface and wiring diagram



### Power supply connector(CN1)

CN1	Input/Output	Function description
V-	Input	Power supply -
V+	Input	Power supply + (DC24-75V)

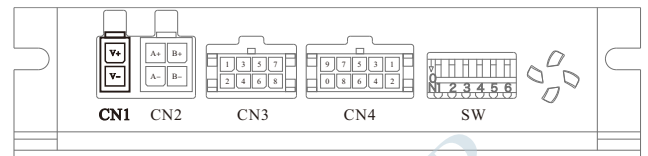

### Motor connector(CN2)

CN2	Input/Output	Function description
B-	Input	Motor phase B-
B+	Input	Motor phase B+
A-	Input	Motor phase A-
A+	Input	Motor phase A+

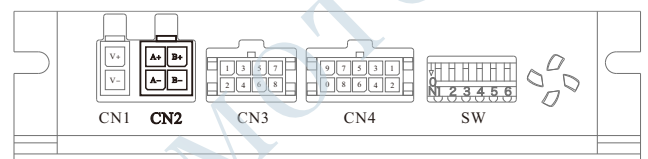

### Encoder connector(CN3)

编号	Connector	Input/Output	Function description
1	GND	Output	GND
2	5V	Output	+5V power supply for encoder
3	NC	-	No connection
4	NC	-	No connection
5	B-	Input	Encoder B-
6	B+	Input	Encoder B+
7	A-	Input	Encoder A-
8	A+	Input	Encoder A+

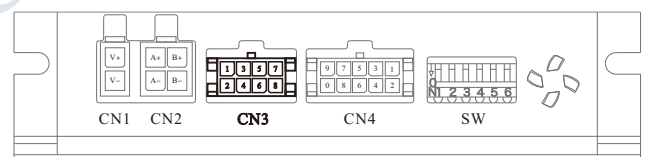

● Control signal connector(CN4)

No.	Connector	Colour	Input/Output	Function description
1	PUL-	Black green	Input	Pulse Input-/CW Input-
2	PUL+	Green	Input	Pulse Input+/CW Input+
3	DIR-	Black white	Input	Direction Input- /CWW Input-
4	DIR+	Black	Input	Direction Input+/CWW Input+
5	ENA-	Yellow black	Input	Enable Input -
6	ENA+	Yellow	Input	Enable Input +
7	ALM-	Red white	Output	Fault Output-
8	ALM+	Red	Output	Fault Output+
9	INPOS-	Blue black	Output	In position Output-
0	INPOS+	Blue	Output	In position Output+

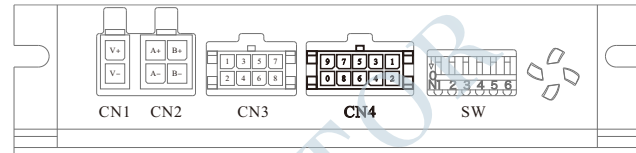

● Function selection switches

Nama	Function description
SW1~SW4	Micro stepping setting
SW5	Initial direction selection
SW6	Single/double pulse matching

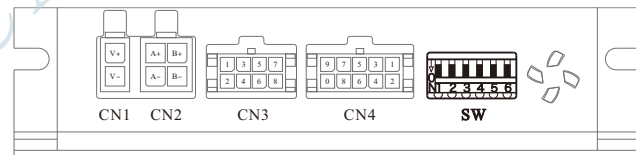

## ■ Connecting the motor

Closed loop stepper motor has two output cable, one is for motor and another is for encoder.

### ● Motor cable

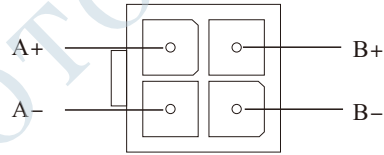

### ● Encoder cable

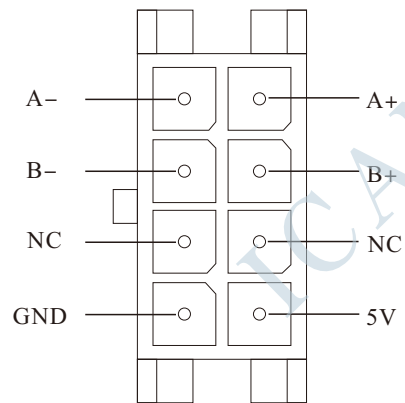

**Don't tear motor/ encoder cable to damage the motor.**  
 (For example, taking motor with cable, put heavy things on it)

## ■ Description of Input/output Signals

SS57 closed stepper motor driver input/output terminal:

- 6 line optically isolation digital sign input, 5-24V
- 2 line optically isolation digital sign output, 30V/100mA

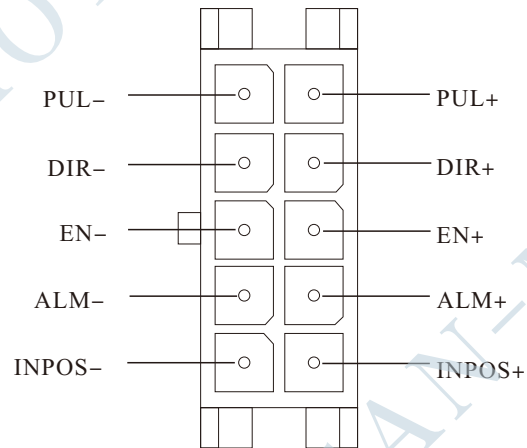

## Input

### Input signal

The signal input is OC input, the voltage is DC5V-24V. The largest frequency of pulse and direction signal is 500KHZ. The pulse rising edge is valid.

#### Common anode

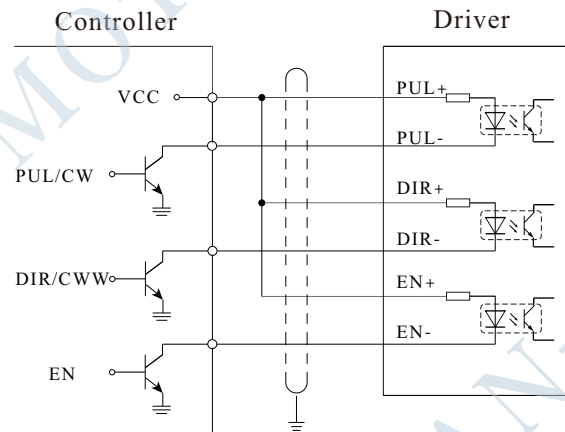

#### Common cathode

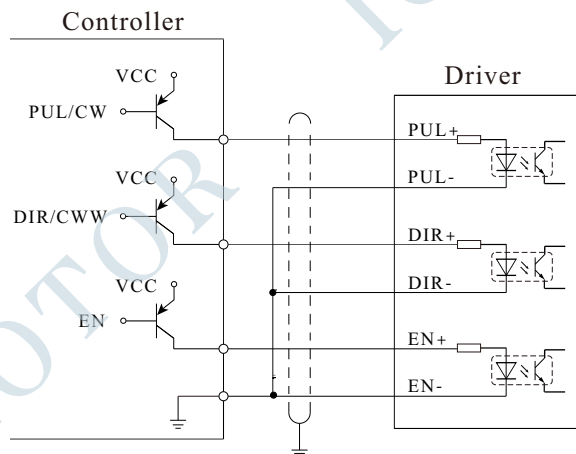

#### Difference

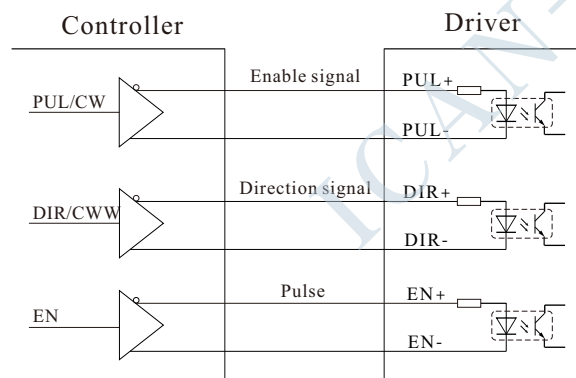



## Output

### Alarm signal output

Alarm signal is OC. The largest voltage is 30V and the largest current is 100mA

 **Notice: Don't connect output with voltage over 30V, 100mA**

Common anode

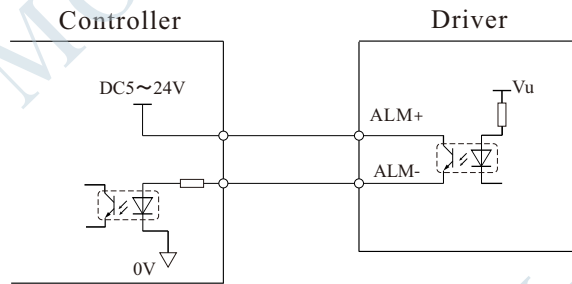

Common cathode

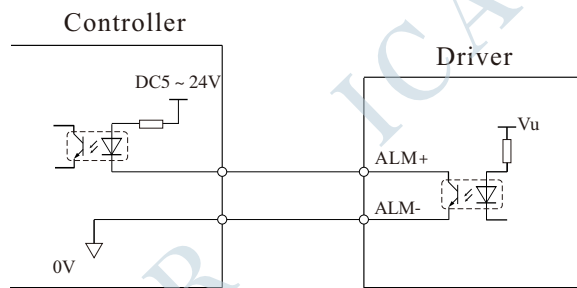

Relay

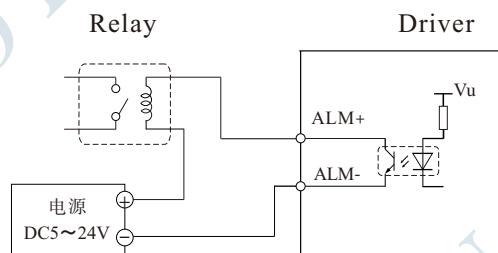

### In Position Output signal

When the motor is running, the INPOS is high level, when the motor stops, INPOS is low level.

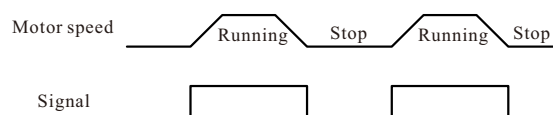

## Function setting

### Microstepping

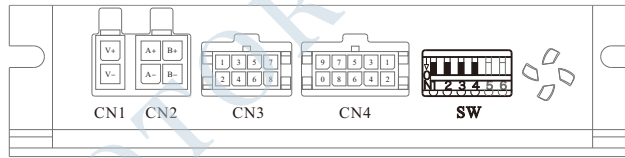

The microstep resolution is set by the SW1, SW2, SW3 and SW4 switches. There are 16 settings.

Subdivision (Step/r)	SW1	SW2	SW3	SW4
200	ON	ON	ON	ON
400	OFF	ON	ON	ON
800	ON	OFF	ON	ON
1600	OFF	OFF	ON	ON
3200	ON	ON	OFF	ON
6400	OFF	ON	OFF	ON
12800	ON	OFF	OFF	ON
25600	OFF	OFF	OFF	ON
1000	ON	ON	ON	OFF
2000	OFF	ON	ON	OFF
4000	ON	OFF	ON	OFF
5000	OFF	OFF	ON	OFF
8000	ON	ON	OFF	OFF
10000	OFF	ON	OFF	OFF
20000	ON	OFF	OFF	OFF
25000	OFF	OFF	OFF	OFF

### Initial direction selection

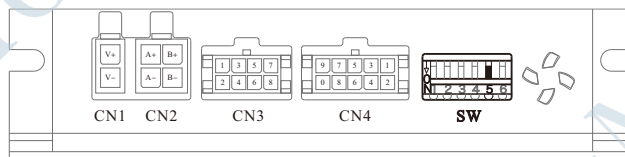

SW5=ON, Motor rotates anticlockwise; SW5=OFF, Motor rotates clockwise (factory setting)

#### Motor rotates anticlockwise

When motor rotates anticlockwise, status LED flickers as Green-Yellow-Red-Blue-Green.

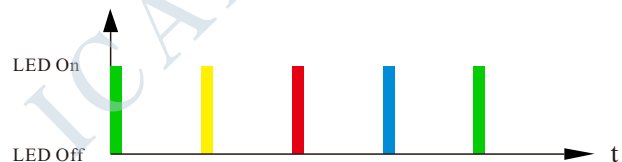

#### Motor rotates clockwise

When motor rotates clockwise, status LED flickers as Green- Blue-Red-Yellow-Green.

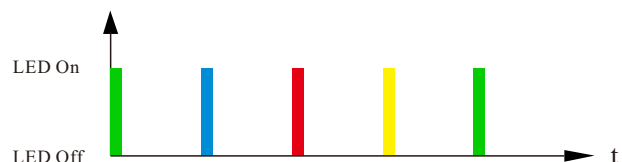

● Pulse&Direction mode selection

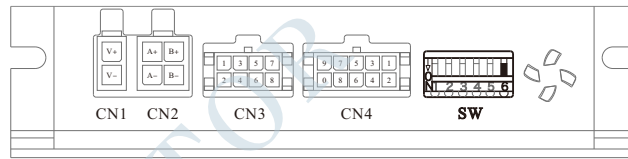

SW6=OFF, Pulse&Dir Mode; SW6=ON, CW&CCW Mode

**!** The setting will take effect after recycle the power

**CW/CCW Pulse**

When pulse is input at PUL/CW terminal, the motor will rotate by one step in one direction.

When pulse is input at DIR/CWW terminal, the motor will rotate by one step in the other direction.

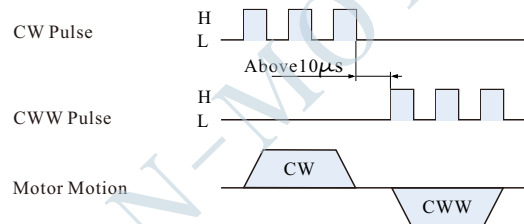

**Pulse & Direction**

When pulse is input at PUL terminal, and DIR terminal is high voltage, the motor will rotate by one step in one direction.



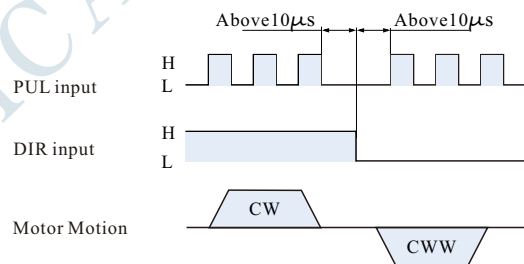



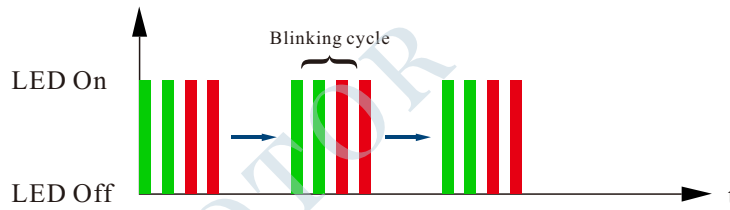

When pulse is input at PUL terminal, and DIR terminal is low voltage, the motor will rotate by one step in the other direction.



## LED Error Codes



When alarm LED is on, please check the reason as following tab.

LED	Motion status/Alarm
 Green, yellow, red, blue circulation flashing	Motor rotates clockwise normally
 Green, blue, red, yellow circulation flashing	Motor rotates anticlockwise normally
 2 green, 2red circulation flashing	Over current protection
 2 green, 3red circulation flashing	Open circuit protection
 2 green, 4red circulation flashing	Over voltage protection
 2 green, 5red circulation flashing	Under voltage protection
 3 green, 2red circulation flashing	Overload protection
 Flashing blue	In position output
 Flashing red	Enable status



**Notice:** Turning on power is banned when driver hasn't been connected with motor, power positive and negative pole will ruin the driver.

## Recommended motor

### Nema 17 closed loop stepper motor

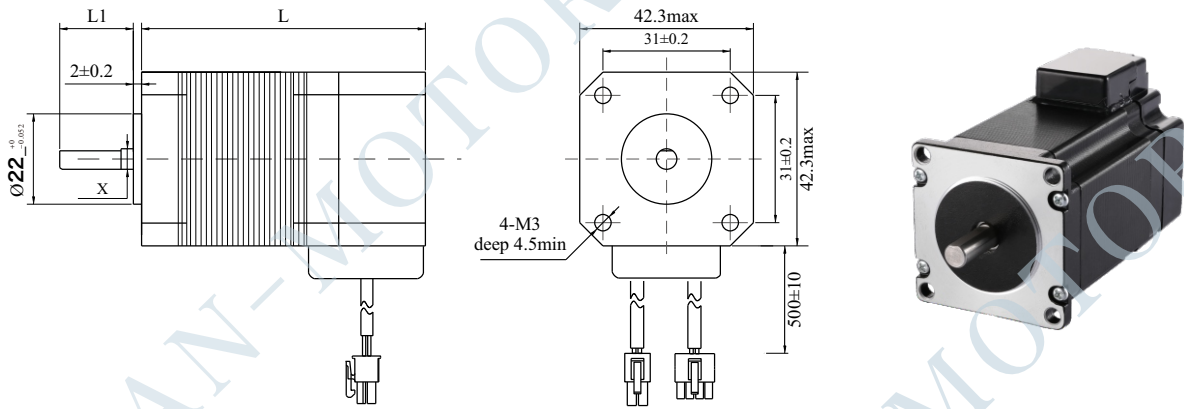

Model	Holding Torque(Nm)	Current/phase(A)	Resistance (Ω)	Inductance (mH)	Diameter of axle X(mm)	Axial length L1(mm)	Motor Length L(mm)	Encoder Resolution
SM4201A-1000AO	0.25	1.2	3.2	4.4	5	18	54	1000
SM4202A-1000AO	0.35	1.0	5.7	9.0	5	18	60	1000
SM4203A-1000AO	0.46	1.2	3.5	6.0	5	18	68	1000
SM4204A-1000AO	0.75	1.7	2.5	6.7	5	18	80	1000

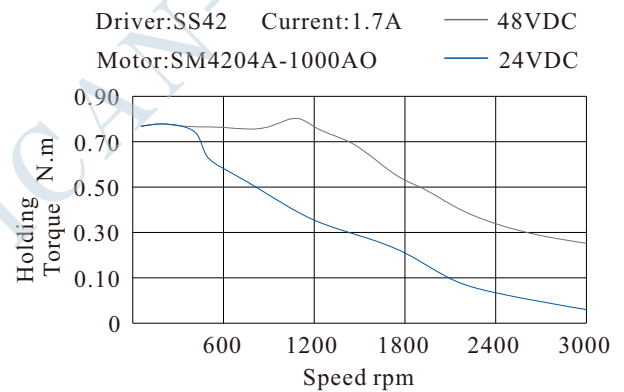
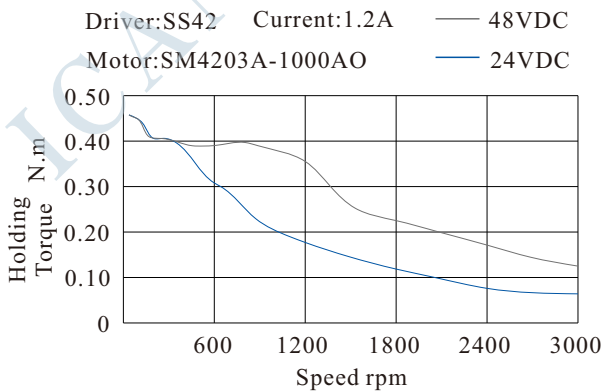
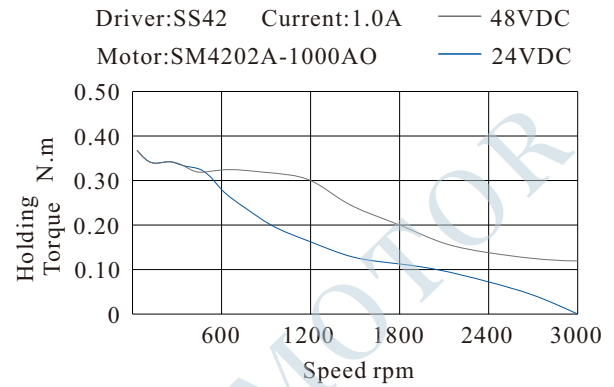
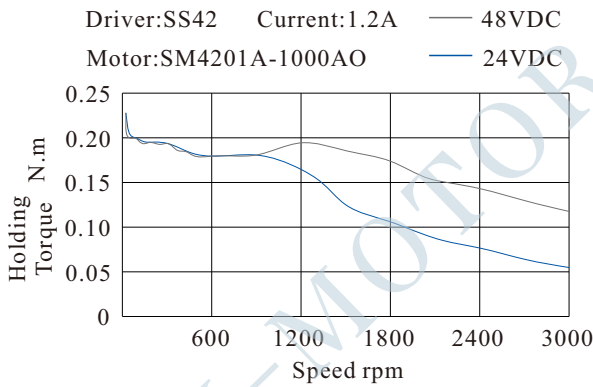

## Accessories

### Naming rule for motor cable

<b>SW</b>	<b>-</b>	<b>50</b>	<b>G</b>	<b>M</b>	<b>03</b>
Series name		Cable cross section	Cable category	Cable use	Cable length
SW: SW series			G: Universal cable F: High soft cable	M: Motor cable	01: 1M 03: 3M 05: 5M

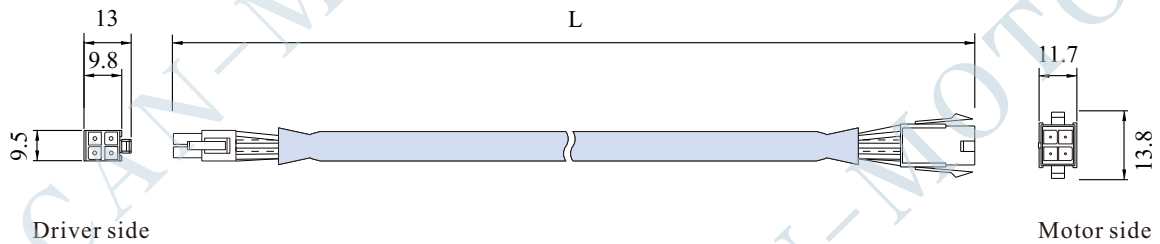

### Naming rule for encoder cable

<b>SW</b>	<b>-</b>	<b>14</b>	<b>F</b>	<b>E</b>	<b>03</b>
Series name		Cable cross section	Cable category	Cable use	Cable length
SW: SW series			F: High soft cable	E: Encoder cable	01: 1M 03: 3M 05: 5M

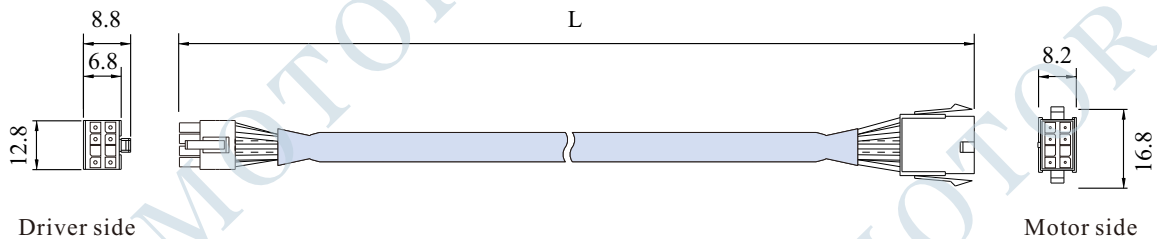

### Cable list

Name	Cable material	Model number		
		Cable 1M	Cable 3M	Cable 5M
Motor cable	General (not resistant to bending)	SW50GM01	SW50GM03	SW50GM05
	High soft (resistant to bending 500W times)	SW50FM01	SW50FM03	SW50FM05
Encoder cable	High soft (resistant to bending 500W times)	SW14FE01	SW14FE03	SW14FE05



1. Make sure all the cable terminals are connected well to avoid short circuit and damage the driver
2. Use Shielded Twisted Pair(STP) as encoder and control line to enhance anti-jamming capability.

## After sale service

### Warranty period

Dongguan ICAN Technology provides warranty for 1 year from the date of shipping.

### Maintenance process

- 1) Get the maintenance permission
  - 2) Ship the package to the following address: 4/F, Block B, RuiLian Zhenxing Industrial Park, Wanjiang District, Dongguan City, Guangdong Province
- Tel: 86-0769-22327568

### Return policy

1. After use or man-made damage condition (etc, wrong wiring), no return
2. ICAN Technology guarantees the product quality, but product incompatibility is not in the return or maintain condition.
3. Customers don't use the products under the specified electrical performance and environment indicators, no maintain condition



### Dongguan ICAN Technology Co., Ltd

Add:4/F, Block B, RuiLian Zhenxing Industrial Park, Wanjiang District, Dongguan City, Guangdong Province, China

Tel: 086-0769-22327568

Fax:086-0769-22327578

Website: [ican-tech.en.alibaba.com](http://ican-tech.en.alibaba.com)



Scan the QR code to follow us on Wechat