



SEH750RA

Instruction book



Catalogue

1 Brief Instruction	2
1.1 Features	2
2.1 Electrical Performance	2
4 Driver port and function description	3
4.1 Driver port	3
4.2 Terminal Description	4
4.3 Description of external control signal circuit	4
4.4 Output circuit description	5
5 Introduction to panel functions	6
5.1 Panel functions	6
5.2 Panel introduction	7
6.1 Start and stop	9
6.2 Direction control	9
6.3 Speed regulation mode	9
6.4 RS485	11
7.2 ALARM RESET	15
8 Troubleshooting	15
After Sales Service	16

BLDC MOTOR DRIVER

SEH750RA

1 Brief Instruction

The SEH750RA BLDC Driver is suitable for high voltage three-phase BLDC Motor with a power of 750W and below. This product has display, easy to operate, supports RS-485 communication protocol, can provide built-in potentiometer speed regulation, external potentiometer speed regulation, analog voltage speed regulation.

1.1 Features

- Self-contained digital tube display, intelligent display of various parameters
- Adjustable speed with knob
- External potentiometer speed regulation
- Acceleration and deceleration time setting
- Pole pair setting
- Alarm display
- RS485
- Rated speed accuracy as low as $\pm 0.5\%$

2 Electrical performance and environmental indicators

2.1 Electrical Performance

Parameters	Min	Rated	Max	Unit
Voltage Input	120	220	250	VAC
Current Input	-	7	-	A
Current Output	-	-	12	A
Power output	-	750	750	W
Motor Speed	-	3000	Adjustable	rpm

The parameters of this table are suitable for normal temperature 25 °C

2.2 Environmental Indicators

Environmental Factor	Environmental indicators
Cooling mode	Air cooling
Use occasion	Avoid dust, oil stain and corrosive gas
Operating temperature	-10°C~+60°C

3 Mechanical Dimensions

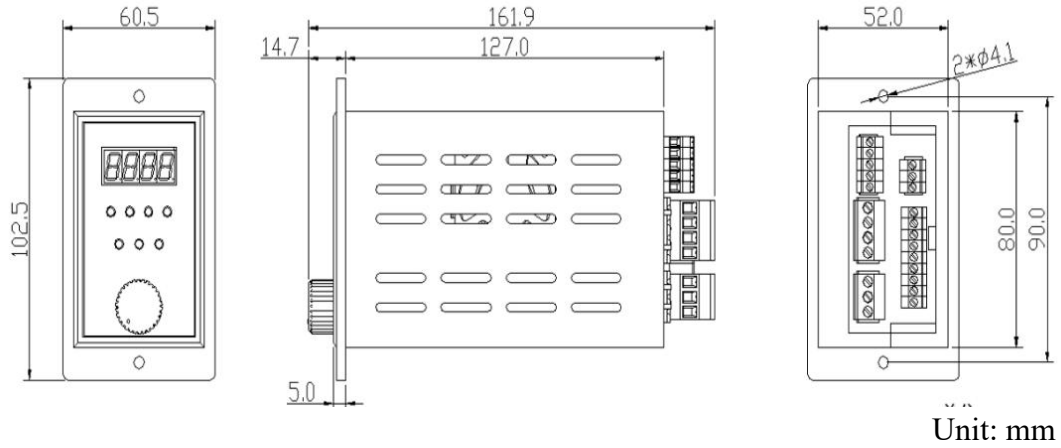

4 Driver port and function description

4.1 Driver port

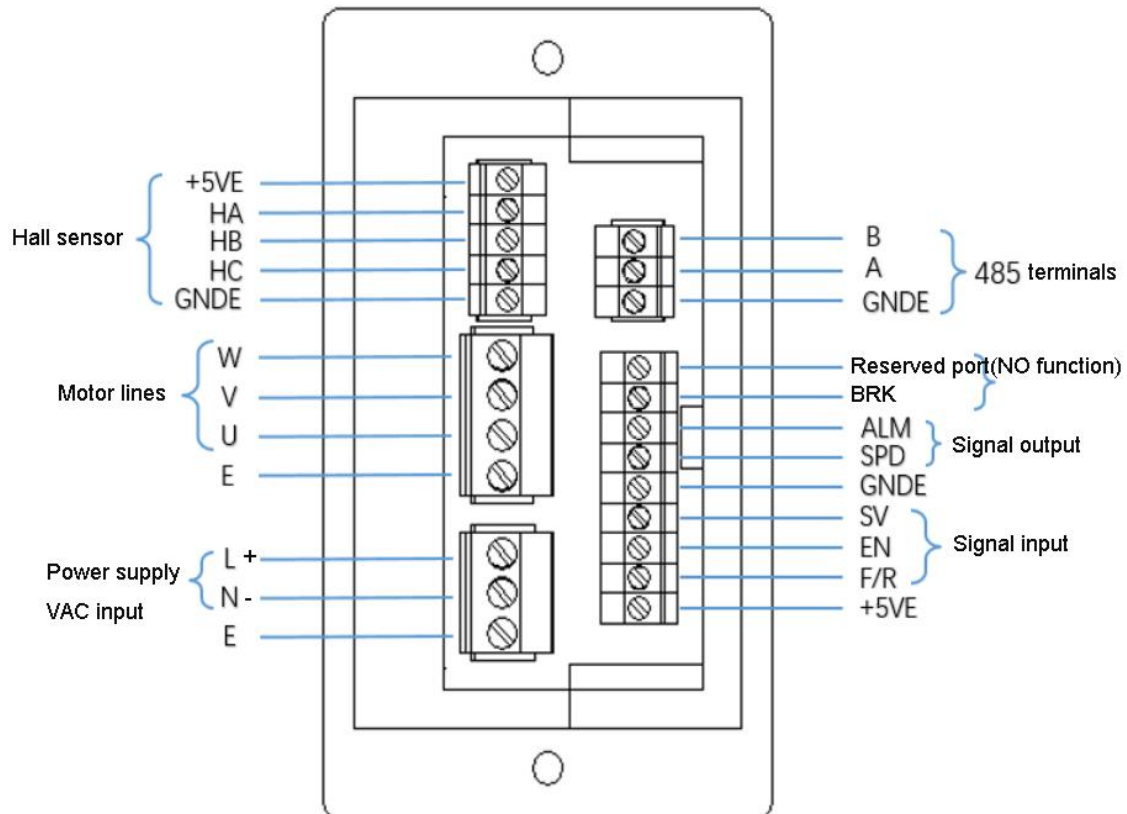

4.2 Terminal Description

Signal	Terminals	Description
Power input	L	Power+
	N	Power-
	E	Ground
Motor lines	U	Motor U
	V	Motor V
	W	Motor W
	E	Ground
Motor hall lines	+5VE	Hall sensor +
	HA	Motor hall sensor Hu
	HB	Motor hall sensor Hv
	HC	Motor hall sensor Hw
	GNDE	Hall sensor -
Control signals	SV	External potentiometer speed regulation
	EN	If EN and GNDE connect, the motor runs; If EN and GNDE disconnect, the motor stops. (They disconnect by default.)
	F/R	If F/ and GNDE connect, the motor runs anti-clockwise If F/ and GNDE disconnect, the motor runs clockwise
	GNDE	Control signal common ground port
	BRK	Under port control mode P-03-4, BRK connects with GNDE, the motor brake stops
Output signals	SPD	Frequency output. The relationship between the frequency detected and the speed is: $N(\text{rpm}) = F$ F: Output pulse frequency(Hz) N: Motor speed For example: $F=500\text{Hz}$, then $N(\text{rpm})=500$ (Note: Motor poles should be set rightly)
	ALM	It is a high resistance output, and when a fault occurs, it outputs a low level

4.3 Description of external control signal circuit

The F/R and EN terminals are as below, amplitude ranges less than 0.5V, or higher than 2.5VDC

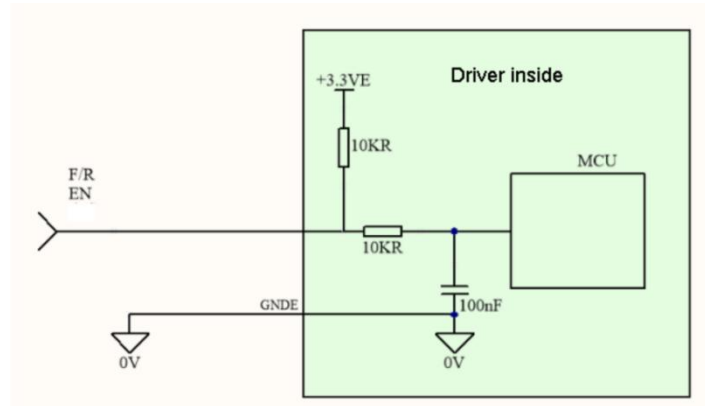

The external potentiometer SV input wiring is shown below:

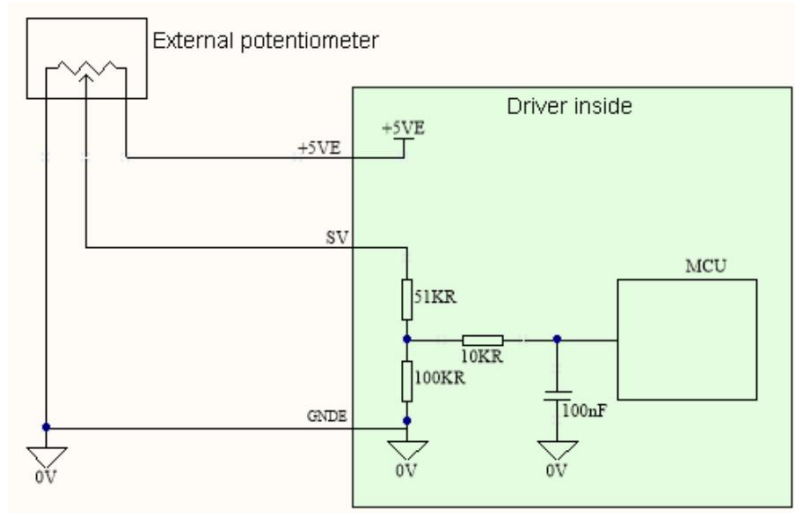

The external analog SV input wiring is shown below:

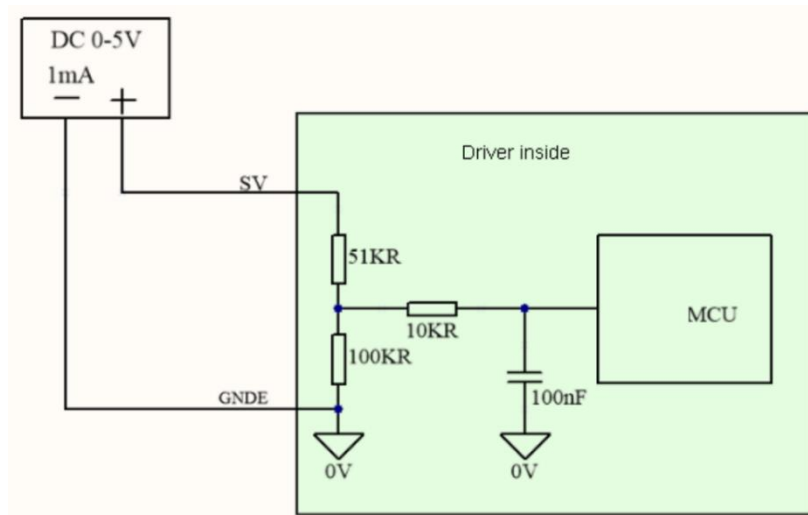

4.4 Output circuit description

ALM and SPD terminals as below, its connection mode with PLC is related to the type of PLC input terminal.

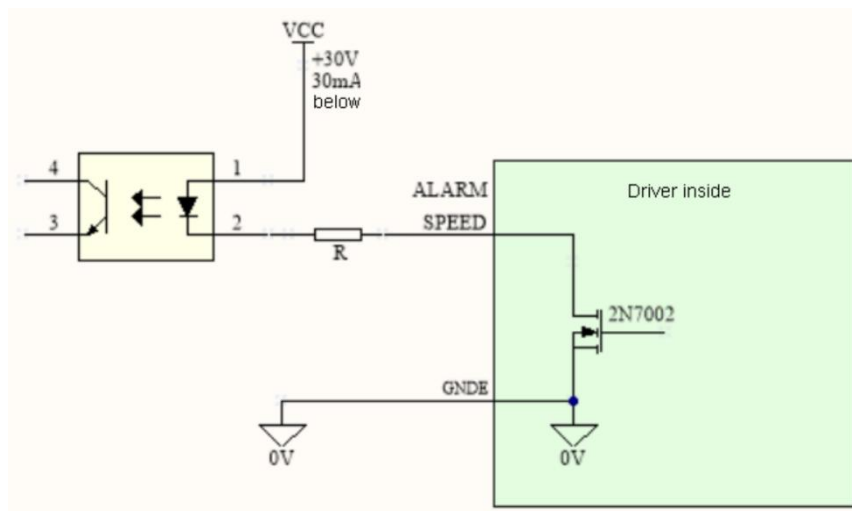

5 Introduction to panel functions

5.1 Panel functions

Functions	Description	Operation mode
Display	Speed display	Display
Temperature display	Drive cooling temperature display	
Speed regulation mode selection	0. Internal knob speed regulation	Parameter setting
	1. External analog speed regulation	
	2. Key speed regulation or 485 speed regulation	
Speed setting	Step size is 100RPM; The set speed is lower than (400rpm/ pole pairs) and the motor does not rotate;	
Direction setting	0. Motor stops;	
	1. Enter the relevant menu through the panel key to set the forward rotation;	
	2. Enter the relevant menu through the panel keys, and set the reversal	
	3. Motor brakes;	
	4. Direction port control.(F/R, EN)	
Reduction ratio setting	Set the speed ratio of the reducer;	
Alarm reset	Display the alarm code and press SET to reset the alarm	
Polar number setting	Set the pole pairs of the adaptive motor (It is not recommended to change the pole pairs during motor operation);	
Under speed time setting	Set the under speed time. (E.g, set it as 5s, when the speed of the motor is less than 50% of the set speed for over 5s, the motor will stall.)	
Maximum speed setting	Set the upper limit of the speed (it is recommended to set it to the maximum speed of the motor);	
Acceleration and deceleration time setting	Set the ACC and DEC time through the panel keys;	
485 communication address control	Select and control 485 communication address in steps of 1;	
485 communication rate setting	Set the 485 communication rate in steps of 1;	
Port indication	Indicates the status of each IO port, read-only;	
Data initialization	Restore the operation data to the factory setting;	

5.2 Panel introduction

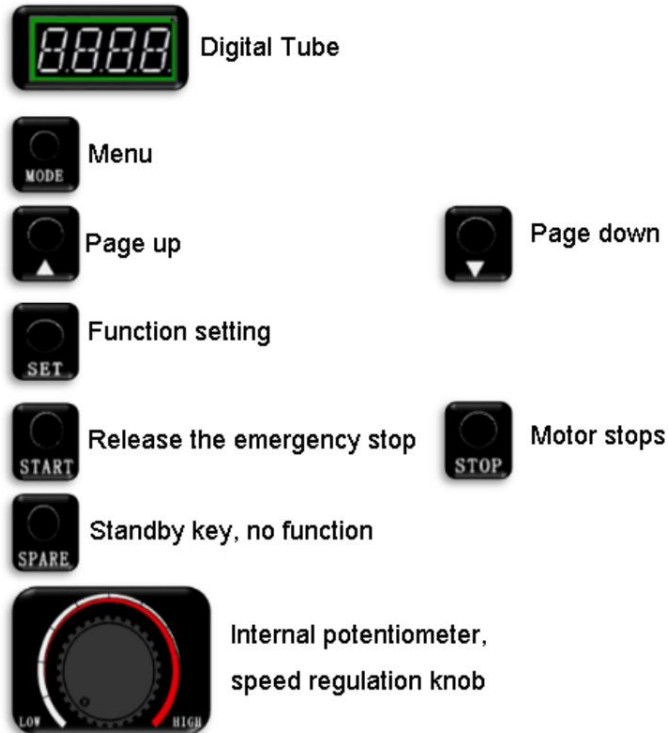

5.3 Drive panel control settings

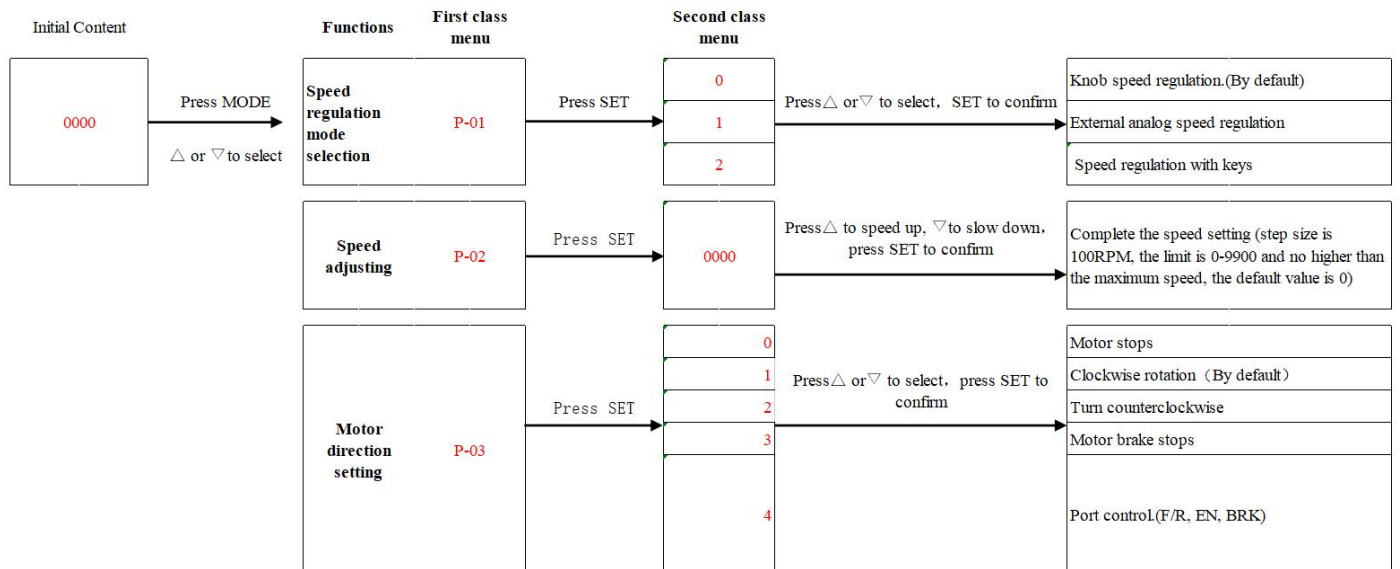



Brushless Motor Driver SEH750RA

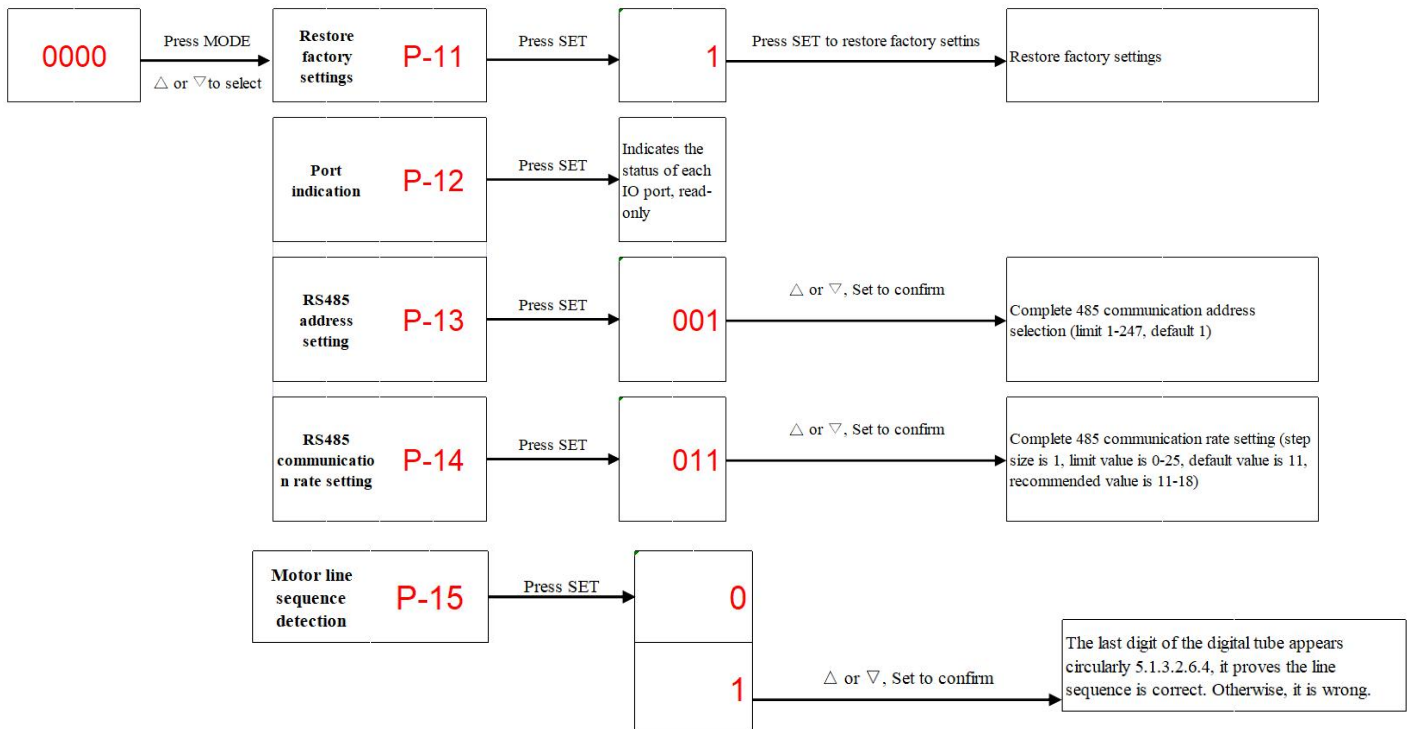
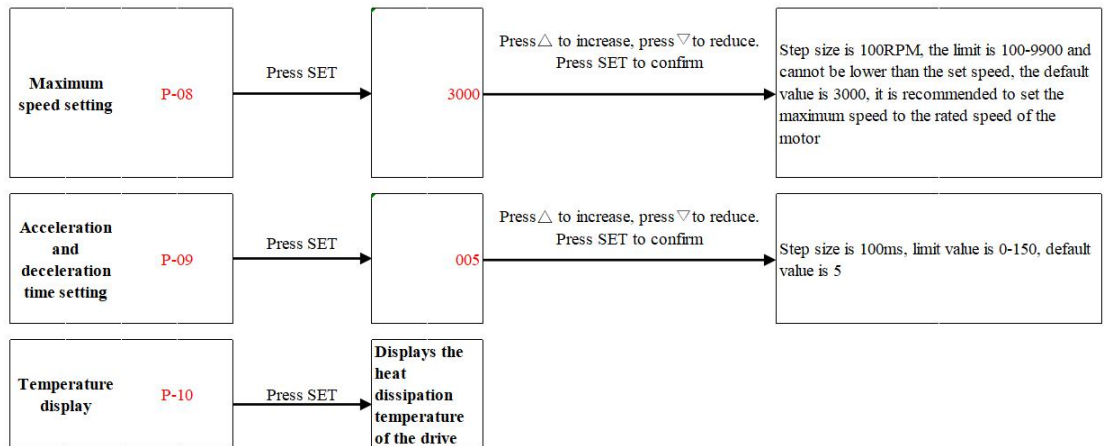
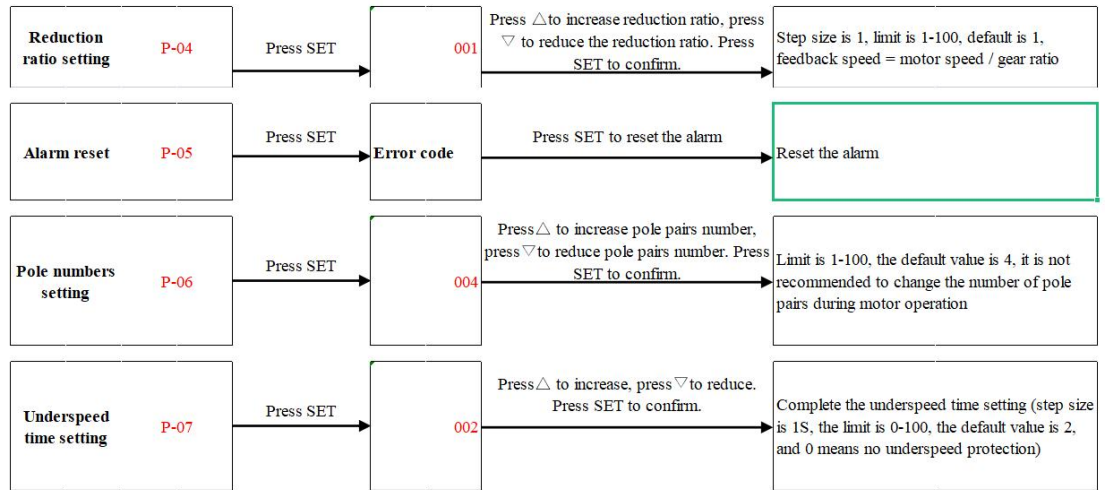

Note: All settings will be saved automatically immediately, even power off without loss.

6.Function setting of external control port.

6.1 Start and stop

EN and GNDE are disconnect by default, When the power is turned on, the motor will not rotate. There are two ways to start the motor:

1. Press START to start and STOP to stop the motor.
2. Connect EN and GNDE. A switch or PLC can be added between EN and GNDE to control the motor start and stop. See right.

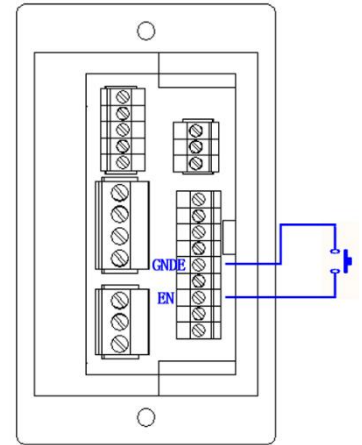

6.2 Direction control.

Here are two methods to control the direction.

1. Through the panel MODE->P-03.
2. Disconnect F/R and GNDE, motor runs clockwise.
Connect F/R and GNDE, motor runs anti-clockwise.

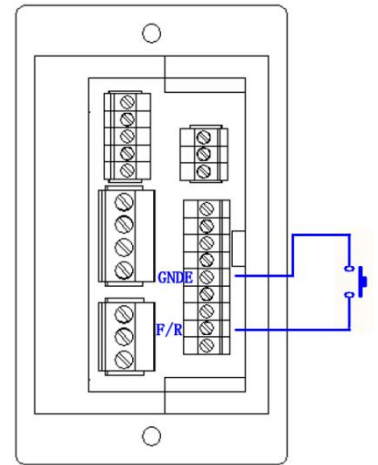

6.3 Speed regulation mode.

6.3.1. Knob speed regulation.(Default method.)



Internal potentiometer,
speed regulation knob

6.3.2 MODE->P-01->SET->2 to select speed regulation with keys, press page up or page down to select request speed.

6.3.3 In addition to using the built-in potentiometer knob on the panel for speed regulation, the **external port SV** can be used for the following settings for speed regulation. To start, set MODE->P-01->SET->1.

1. External potentiometer speed regulation.

10K Ω is recommended to adjust the speed.
Connect the central pin of the external potentiometer to the SV terminal, and connect the other two pins to the GNDE port and the +5VE port respectively.
(Refer to the picture below for details)

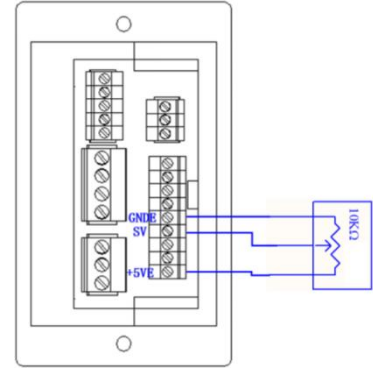

2. External analog signal role DC 0-5V

Note: Be sure to set the correct number of motor pole pairs.

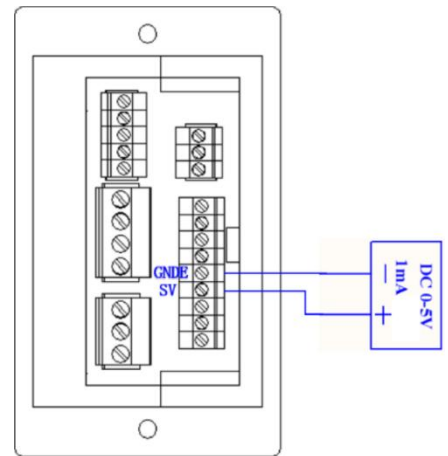
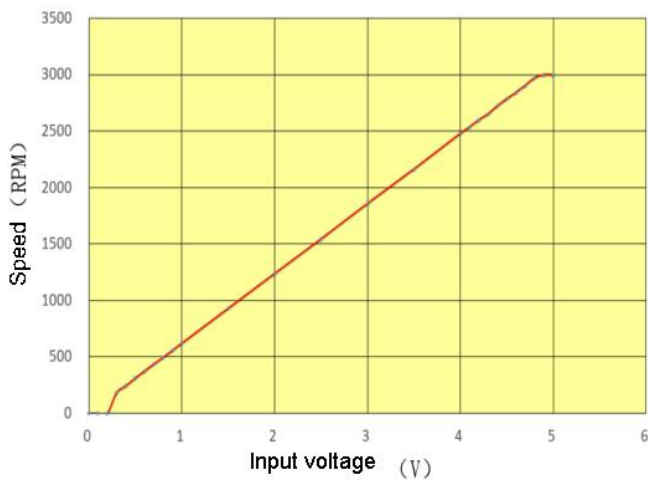

(Relationship between speed command voltage and motor speed)

The above is the measured diagram of a 3000rpm motor. When the input voltage is 0.3V, the motor speed is 183rpm. When the input voltage is about 5V, the motor speed is 3000rpm.

6.4 RS485

The communication function of this driver adopts Modbus protocol, which conforms to the standard GB/T 19582.1-2008. Using RS485-based two-wire serial link communication, the physical interface adopts 3.81mm, 3PIN plug-in terminal, the terminal definition is shown in the figure below, and three wires need to be connected: B, A, GNDE. The communication address can be set through the panel operation. The 120Ω terminal matching resistance needs to be externally connected by the user.

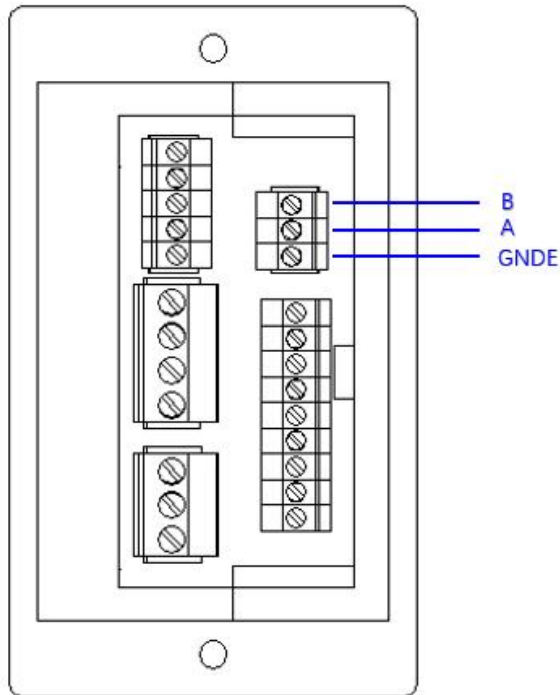

Communication conditions	
Interface	3.81mm、3PIN Plug-in terminal block
Bus	RS485
Protocol	MODBUS
Communication mode	Half duplex
Standard	GB/T 19582.1—2008
Communication rate	9600 (can be set)
Data bit	8 bit
Stop bit	1 bit
Check	ModbusCRC low order first
Communication node	247



Brushless Motor Driver SEH750RA

Refer to the following table for the address of read / write register:

READ									
Slave address (1byte)	Function code (1byte)	Access address 1* (2byte)	Access address 2* (2byte)	Access data (2byte)	CRC Check (2byte)	Read parameters	Value Range	Default value	Unit
0Xnn	0X03 (Read data)	0X0000	0X0054	0X0001	CRC Check	Speed mode selection	0-2	0	
		0X0001	0X0056			Speed setting	0-Max speed	0	RPM
		0X0002	0X005F			Speed Value	0-65535	0	RPM
		0X0003	0X0066			Motor direction	0-4	1	-
		0X0004	0X0068			Gear ratio	1-100	1	-
		0X0005	0X0076			Alarm code		0	-
		0X0006	0X0086			Pole pairs number	1-100	4	
		0X0007	0X0090			Under speed time read	0-100	2	s
		0X0008	0X0092			Max speed	100-65535	3000	RPM
		0X0009	0X0098			ACC/DEC time	0-150	5	0.1s
		0X000A	0X00D2			Temperature	-300-1250	-	0.1°C
		0X000B	0X0113			Program version	-	-	-
		0X000C	0X0129			Port indication	-	-	-
		0X000D	0X012A			Port indication	-	-	-

*: Access address 1 and access address 2, you can choose one of the two, access address 1 is easy to read, and access address 2 is recommended to use 0X0001 to access data.



The write register address can refer to the following table:

WRITE								
Slave address (1byte)	Function code (1byte)	Access address (2byte)	Access data (2byte)	CRC Check (2byte)	Write parameters	Value Range	Default value	Unit
0Xnn	0X06 (Write data)	0X0054	0X0000	CRC Check	Speed adjusting mode	0-2	0	-
		0X0056	0X0000		Speed setting	0-Max speed	0	RPM
		0X0066	0X0001		Motor direction setting	0-4	1	-
		0X0068	0X0001		Gear ratio setting	1-100	1	-
		0X0076	0X0001		Alarm Reset	-	-	-
		0X0086	0X0004		Pole pairs setting	1-100	4	-
		0X0090	0X0002		Under speed time	0-100	2	s
		0X0092	0X0BB8		Max speed	100-65535	300	RPM
		0X0098	0X0005		ACC/DEC time setting	0-150	5	0.1s
		0X00BC	0X0001		Parameter saving	-	-	-
		0X00CC	0X0001		Factory setting recovery	1		

Parameter description refer to the table below:

Parameters	Description or note
Speed adjusting modes selection	0: Knob speed regulation; 1: External analog quantity; 2: key or communication;
Speed setting	The motor does not rotate when the set speed is lower than (400RPM/pole pair number)
Speed feedback	If the reduction ratio is set, the final speed is speed / reduction ratio
Direction setting	0: Stop; 1: Clockwise; 2: anti-clockwise; 3: Brake; 4:Port control (F/R, EN)
Gear ratio setting	Note: Speed = motor speed / gear ration;
Alarm code	Read: read alarm code; write 0x0001: alarm reset;
Poles pairs number	It is not recommended to change the number of pole pairs during motor operation;
Under speed time	0 is for no under speed protection;
Max speed	It is recommended to set the maximum speed to the rated speed of the motor;
ACC/DEC	ACC/DEC time
Temperature	Radiator temperature of the drive
Program version	Read: read program version; write 0x0001: parameter restore factory settings
Port indication	Indicate the status of each IO port (0X0129 is the upper 16 bits);

7 Alarm description and fault handling

7.1 Alarm code description

When over voltage, or the signal of the Hall sensor is wrong, etc., the following situations will occur:

1. The ALM port of the driver is automatically connected to the GNDE port, the ALM port becomes low level, and an alarm signal is sent to the upper computer (In this case, wiring operation is required to send a signal to the upper computer).
2. The motor will stop naturally and the motor output shaft will turn freely.

After a fault alarm occurs, you can press MODE-> P-05 through the display panel and press the SET button to to view the alarm code.

Alarm Code	Alarm name	Alarm Reasons	Troubleshooting
AL00	No error	-	-
AL02	Over temperature	1. There is a foreign object blocking the fan or dust accumulation; 2. The motor does not match the driver; 3. The drive is damaged;	1. Clean the driver; 2. Re-match the motor and driver selection; 3. Replace the driver;
AL05	Hall error	1. Check whether the motor sensor cable is firmly connected 2. Check whether the Hall element in the motor is damaged; 3. Internal communication error of the drive;	Automatic recovery after the fault is cleared;
AL08	Under speed	1. Check whether the set maximum speed is not greater than the rated speed of the motor; 2. Check whether the number of pole pairs is set correctly; 3. Try to stop the motor or power on again to reset the alarm;	The time when the feedback speed is lower than the set speed exceeds the set underspeed time, and the default underspeed time is 2 seconds;
AL09	Module alarm	IPM Power Module Alarm	1. Detect whether there is dust entering; 2. Try to lengthen the acceleration and deceleration time; 3. Re-power; 4. If the alarm still occurs, replace the driver
AL10 — AL26	Hardware failure	Please check for iron filings, corrosion, dust	Re-power on, if it still doesn't work, replace the controller;
AL40 — AL43	Storage error	Please check for iron filings, corrosion, dust	

7.2 ALARM RESET

If the above solutions don't work, follow the operations below to reset the alarm signal

1. **MODE->P-05->SET** to check the alarm code, then press SET to reset the alarm.
2. Cut off the power supply, then power on again after 1 minute, the alarm can be released.

8 Troubleshooting

Phenomenon	Possible reason	Troubleshooting
Motor stop	Alarm	Do as alarm code
	Press Stop	Press Start
	Wrongly motor lines	Check the wiring and phase
	Motor brake is wrong	Make sure the motor brake is open
	Driver doesn't match the motor	This driver only supports motors with a Hall electrical angle of 120°
	Damage	Replace new motor and driver
Over heat	Over load	Make the load lower
	Over current	Make the current lower
	The ambient temperature is too high	Improve environmental heat dissipation.
	Wrong phase	Correct phase connection
	Damage	Replace new motor and driver
Abnormal motor speed	Overload	Make the load smaller
	Signal input wrongly	Signal input checking
	Wrong poles pairs numbers setting	Set the right poles numbers
	Wrong gear ratio setting	Set the right gear ratio
	Wrong max speed setting	Set the maximum speed to the rated speed of the actual motor
The motor is running with abnormal noise	Phase wrongly	Check the motor phase
	Driver doesn't match the motor	This driver only supports motors with a Hall electrical angle of 120°
	Lack of phase wiring	Check the motor phase
	Load problem	No load operation motor test
	Motor problem	Change the motor
Motor speed fluctuations	Signal input wrongly	Change to knob speed setting to check if there is the same error
	The load inertia ratio is too large	Decrease load inertia ratio or increase gear box
	The load is changeable	Steady load or this condition is normal
No signal output	Pull-up resistor not connected	The alarm output interface and the speed output interface are connected with appropriate pull-up resistors

After Sales Service

Warranty:

The warranty is 12months from the date of shipment. We offer free technical support during the time.

Repair progress:

- (1) Contact the sales to tell the details.
- (2) Send back the product to:

Room 401, Building 2, No. 7, Xinhe Shengfeng Road, Wanjiang Street, Dongguan City, Guangdong Province, China

Warranty Limitations

Damage caused by improper use of products is not covered by the warranty.

Product damage caused by the use environment or electric parameters that does not meet the use parameters is not covered by the warranty.

Product damage caused by improper selection is not covered by the warranty.

Product damage caused by unauthorized processing, repair, transformation, or decomposition of this product is not covered by the warranty.

Product damage caused by improper wiring, such as reverse polarity of the power supply and live plugging and unplugging of the motor leads, is not covered by the warranty

Technical support	Consultation on the selection method and use method of motor and driver Hotline: 400-696-4446 TEL:0769-22327568 Time: Monday-Friday 9:00~12:00、 13:00~17:00
Data download	https://www.ican-motor.com