

电机尺寸
DIMENSIONS:
(UNIT=MM)

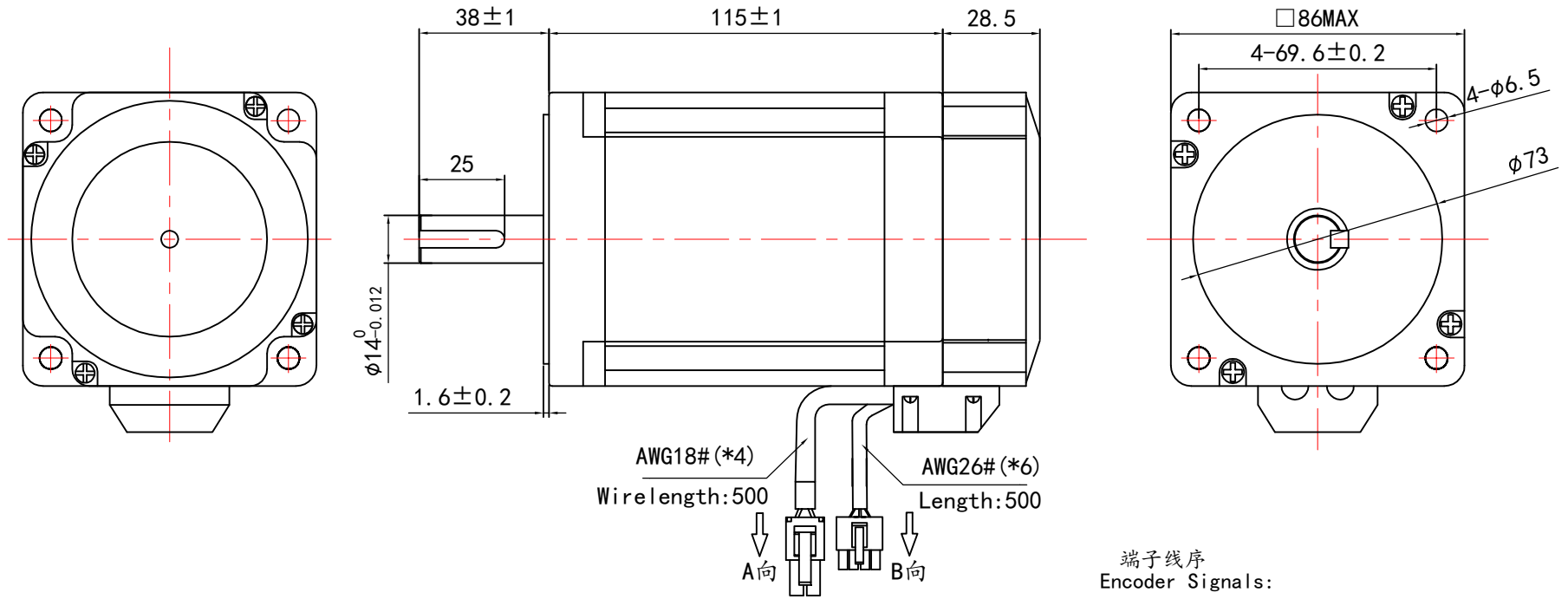

端子线序
Encoder Signals:

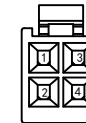

PIN	1	2	3	4
颜色	黑	绿	红	蓝
定义	A+	A-	B+	B-

A向

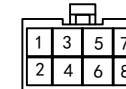

PIN	1	2	5	6	7	8
颜色	红白	红	蓝黑	蓝	黑白	黑
定义	GND	5V	B-	B+	A-	A+

B向

电机参数/ELECTRICAL PARAMETER	
步距角 STEP ANGLE (° /STEP)	1.8
电机电压 RATED VOLTAGE (V)	2.76
电机电流 RATED CURRENT (A/PHASE)	6.0
电机电阻 RESISTANCE (Ω±15%/PHASE)	0.46
电机电感 INDUCTANCE (mH±20%/PHASE)	5.8
电机力矩 HOLDING TORQUE (N.M)	8.5
编码器分辨率 ENCODER RES	1000
电气强度 ELECTRIC STRENGTH	AC 500((V/1min/5mA MAX)
转子惯量 THE ROTOR INERTIA(g·cm ²)	3600
绝缘等级 INSULATION GRADE	B
重量 WEIGHT (KG)	≈3.8

说明NOTES:

- PLEASE DON'T HOLD MOTOR BY LEAD WIRES.
- PLEASE DON'T PLUG IN/OUT THE MOTOR CONNECTOR WHILE POWER ON.
- PLEASE DON'T DROP, HURL OR DUMP MOTOR AGAINST HARD MATERIAL MALFUNCTION MAY NOT BE OBSERVED AT EARLY STAGE AFTER SUCH SHOCKS, BUT FOUND LATER. THE MISHANDLING VOIDS OUR WARRANTY.
- DONGGUAN ICAN-TECH WILL NOT BE RESPONSIBLE FOR ANY PATENT DISPUTE OR PROBLEM CAUSED BY ACTUAL APPLICATIONS

轴径配置/SHAFT DESIGN

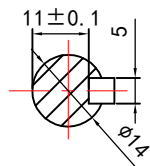

电机接线图 Connection Mode

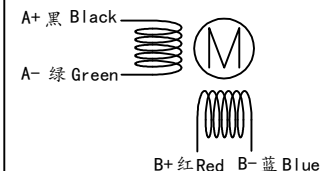

制图 DESIGNED

JIAJIANG

检图 CHECKED

CHENSHENG

SM8603AA-1000A0-CC

闭环步进电机
STEPPER SERVO MOTOR

校准 APPROVED

日期 DATE

2021/11/3

比例 SCALE

1:1

东莞市一能机电技术有限公司
DONGGUAN ICAN TECHNOLOGY CO., LTD



第一视角

单位

MM

版本

EDITION

V1.0